

ø22 Switches & Pilot Lights

YW Series



Innovative Design, Space-Saving, Safety,
and Self-Cleaning Contacts



• See website for details on approvals and standards.

Emergency Stop Switches

Satisfy International Standards

- Safety Lock Mechanism
- Direct Opening Action →
- Safe Pushbutton Design



Non-illuminated Illuminated

Easy Operation

- Push-to-lock, Pull/Turn-to-release

YW emergency stop switches can be unlatched by either pulling or turning the operator.



Unlatching by pulling



Unlatching by turning

Unibody Pilot Lights

- Higher Brightness
- Measures only 42mm depth behind the panel
- Four Lens Shapes
- Panel Mounting



Flush Flush w/markings Extended Dome

Key Selector Switches

A variety of operations, key removal positions, and circuits.



Plastic Bezel Metal Bezel

Save

New Contact Block Design

YW series

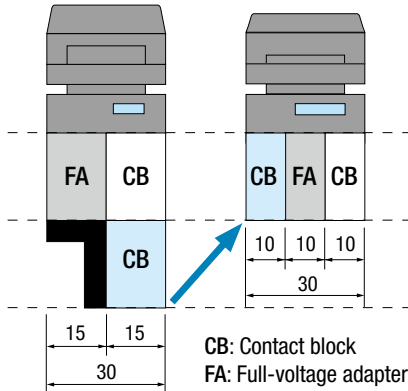

The contact block design reduces the depth behind the panel.



Metal bezels are available for pushbuttons, illuminated pushbuttons, selector switches, and key selector switches.



Reliable

Retained Locking Lever

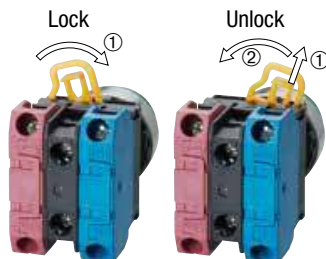

- Heavy-Duty Rugged Construction
- Self-Cleaning Wiping-Action Contacts with Scored Contact Surfaces

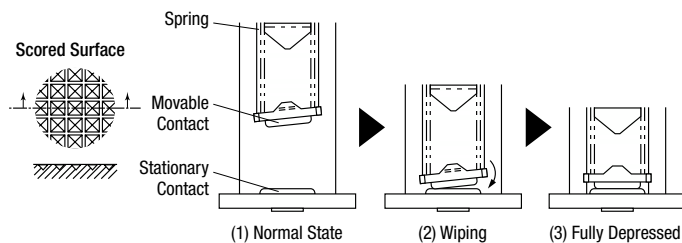

Safety



Integrated Finger-safe Terminal Cover
Degree of Protection: IP20 (From panel front: IP65)

APEM

Switches & Pilot Lights

Control Boxes

Emergency Stop Switches

Enabling Switches

Safety Products

Explosion Proof

Terminal Blocks

Relays & Sockets

Circuit Protectors

Power Supplies

LED Illumination

Controllers

Operator Interfaces

Sensors

AUTO-ID

Flush Silhouette

ø16

ø22

ø30

Miniature

Pilot Lights

HW

TW

YW

 Download catalogs and CAD from <http://eu.idec.com/downloads>

B-270

YW Series Switches & Pilot Lights

Space-saving, 10-mm-thick contact blocks. Removable operator.



APEM

Switches & Pilot Lights

Control Boxes

Emergency Stop Switches

Enabling Switches

Safety Products

Explosion Proof

Terminal Blocks

Relays & Sockets

Circuit Protectors

Power Supplies

LED Illumination

Controllers

Operator Interfaces

Sensors

AUTO-ID

Flush Silhouette

ø16

ø22

ø30

Miniature

Pilot Lights

HW

TW

YW

Contact Ratings (Contact Block)

Rated Insulation Voltage		600V			
Rated Thermal Current		10A			
Operating Voltage		24V	120V	240V	380V
AC	Resistive Load (AC-12)	10A	10A	6A	2A
	Inductive Load (AC-15)	10A	6A	3A	1.9A
DC	Resistive Load (DC-12)	8A	2.2A	1.1A	—
	Inductive Load (DC-13)	4A	1.1A	0.55A	—

LED Illuminated Unit Specifications

Pilot Light (removable lamp terminal type)

Illuminated Pushbutton

Unit Type	Input Type	Unit			Color Code	Lamp Base	LED Lamp			
		Rated Voltage	Operating Voltage				Part No.	Rated Voltage	Current Draw	Color
Pilot Light (removable lamp terminal type)	Full Voltage	6V AC/DC	6V AC/DC	±10%	A: amber G: green PW: pure white R: red S: blue W: white (Note) Y: yellow	BA9S/13	LSED-6②	6V AC/DC	10mA (A, R, Y) 7mA (G, PW, S)	A: amber G: green PW: pure white R: red S: blue Y: yellow
		12V AC/DC	12V AC/DC				LSED-1②	12V AC/DC	14mA (A, R, Y) 13mA (G, PW, S)	
		24V AC/DC	24V AC/DC				LSED-2②	24V AC/DC	14mA (A, R, Y) 13mA (G, PW, S)	
		110V AC/DC	110V AC/DC				LSED-H②	110V AC/DC	5mA	
		230/240V AC/DC	207 to 250V AC/DC				LSED-M3②	230/240V AC/DC	3mA	
Illuminated Pushbutton	Transformer (pilot light only) 50/60 Hz	100/110V AC	100/110V AC	±10%			LSED-6②	6V AC/DC	10mA (A, R, Y) 7mA (G, PW, S)	
		200/220V AC	200/220V AC							
		115/120V AC	115/120V AC							
		230/240V AC	207 to 250V AC							

Note: Yellow LED lamps are used for white illumination.

Pilot Light (unibody type)

Unit Type	Rated Voltage	Operating Voltage	Current Draw	Color Code		
Pilot Light (unibody type)	6V AC/DC	6V AC/DC	16mA (A, R, W, Y) 13mA (G, PW, S)	A: amber G: green PW: pure white R: red S: blue W: white Y: yellow		
	12V AC/DC	12V AC/DC			±10%	
	24V AC/DC	24V AC/DC				20mA
	100/110V AC (50/60 Hz sine wave)	100/110V AC				20mA
	230/240V AC (50/60 Hz sine wave)	230/240V AC				207 to 250V AC

Incandescent Illuminated Unit Specifications

Pilot Light (removable lamp terminal type)

Illuminated Pushbutton

Unit Type	Input Type	Unit			Color Code	Lamp Base	Incandescent Lamp	
		Rated Voltage	Operating Voltage				Part No.	Rating
Pilot Light (removable lamp terminal type)	Full Voltage	6V AC/DC	6V AC/DC	±10%	A: amber G: green R: red S: blue W: white Y: yellow	BA9S/13	LS-T6	1W (6.3V)
		12V AC/DC	12V AC/DC				LS-T8	1W (18V)
		24V AC/DC	24V AC/DC				LS-T3	1W (30V)
Illuminated Pushbutton	Transformer (pilot light only) 50/60 Hz	100/110V AC	100/110V AC	±10%	A: amber G: green R: red S: blue W: white Y: yellow	BA9S/13	LS-T6	1W (6.3V)
		200/220V AC	200/220V AC					
		115/120V AC	115/120V AC					
		230/240V AC	207 to 250V AC					

Specifications

Operating Conditions	Operating temperature: -20 to +55°C (no freezing) Operating humidity: 45 to 85% RH (no condensation) Storage temperature: -45 to +80°C Storage humidity: 95% RH maximum
Degree of Protection	From panel front: IP65 (IEC 60529) Terminal: IP20 (IEC 60529)
Insulation Resistance	100 MΩ
Dielectric Strength	Contact block: 2,500V, 1 minute Pilot light: 2,000V, 1 minute
Vibration Resistance	<Emergency stop switch> Operating extremes / Damage limits: 10 to 500 Hz, amplitude 0.35 mm, acceleration 50 m/s ² (5G) <Pushbutton, pilot light, illuminated pushbutton, selector switch, and key selector switch> Operating extremes: 5 to 55 Hz, amplitude 0.5 mm Damage limits: 30 Hz, amplitude 1.5 mm
Shock Resistance	<Emergency stop switch> Operating extremes: 150 m/s ² (10G) Damage limits: 1,000 m/s ² (100G) <Pushbutton, pilot light, illuminated pushbutton, selector switch, and key selector switch> Operating extremes: 100 m/s ² (10G) Damage limits: 1,000 m/s ² (100G)
Mechanical Life (minimum operations)	<Emergency stop switch> 250,000 (single contact block) <Pushbutton and illuminated pushbutton> Momentary: 5,000,000 (single contact block) 1,000,000 (double contact block) Maintained: 250,000 (single contact block) 100,000 (double contact block) <Selector switch and key selector switch> 250,000 (single contact block) 100,000 (double contact block)
Electrical Life (minimum operations)	<Emergency stop switch> 100,000 (single contact block) <Pushbutton, selector switch, and key selector switch> 100,000 (single contact block) 50,000 (double contact block)

Mounting Hole Layout

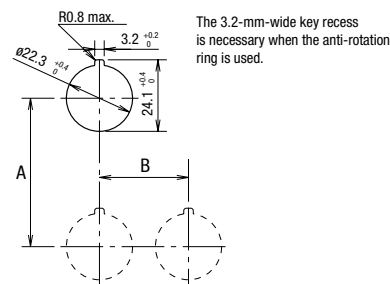

Unit	A (mm)	B (mm)
Emergency stop switch	50 min.	50 min.
Pushbutton	50 min.	30 min.
Selector switch		
Key selector switch	50 min.	40 min.
Mushroom pushbutton		
Pilot light (with removable lamp terminal)	30 min.*	30 min.
Pilot light (unibody)	50 min.	30 min.

* Keep a minimum spacing of 50 mm when using a lamp of over 1W.

APEM
Switches & Pilot Lights

Control Boxes

Emergency Stop Switches
Enabling Switches

Safety Products

Explosion Proof

Terminal Blocks

Relays & Sockets

Circuit Protectors

Power Supplies

LED Illumination

Controllers

Operator Interfaces

Sensors

AUTO-ID

Flush Silhouette

ø16

ø22

ø30

Miniature

Pilot Lights

HW

TW

YW

ø22 YW Series Emergency Stop Switches

Non-illuminated Emergency Stop Switches (Pushlock Pull/Turn Reset)

Package Quantity: 1

Style	Contact	Contact Block Mounting Position			Part No.	Button Color Code
		1	2	3		
	1NC	—	—	NC	YW1B-V4E01R	Red only
	2NC	NC	—	NC	YW1B-V4E02R	
	3NC	NC	NC	NC	YW1B-V4E03R	
	1NO-1NC	NO	—	NC	YW1B-V4E11R	
	1NO-2NC	NO	NC	NC	YW1B-V4E12R	
	2NO-1NC	NO	NC	NO	YW1B-V4E21R	

• When pressed, the button is locked in the depressed position, and is reset when either pulled or turned clockwise.

Dimensions

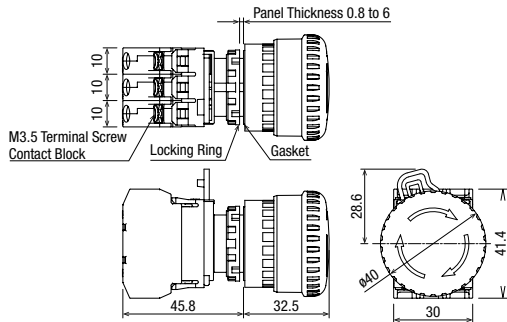

Contact Block Mounting Position



Illuminated Emergency Stop Switches (Pushlock Pull/Turn Reset)

Package Quantity: 1

Style	Lamp	Contacts	Contact Block Mounting Position			Part No.	Ⓢ Operating Voltage Code	Lens Color Code	
			1	2	3				
	Without Lamp	1NC	—	FA	NC	YW1L-V4E01Q0R	0: without lamp 250V AC/DC max.	Red only	
		2NC	NC	FA	NC	YW1L-V4E02Q0R			
		1NO-1NC	NO	FA	NC	YW1L-V4E11Q0R			
	LED	1NC	—	FA	NC	YW1L-V4E01QⓈR	2: 6V AC/DC 3: 12V AC/DC 4: 24V AC/DC H: 110V AC/DC M3: 230/240V AC/DC		
		2NC	NC	FA	NC	YW1L-V4E02QⓈR			
		1NO-1NC	NO	FA	NC	YW1L-V4E11QⓈR			
	Incandescent	1NC	—	FA	NC	YW1L-V4E01QⓈR	5: 6V AC/DC 6: 12V AC/DC 7: 24V AC/DC		
		2NC	NC	FA	NC	YW1L-V4E02QⓈR			
			1NO-1NC	NO	FA	NC	YW1L-V4E11QⓈR		

• Specify an operating voltage code in place of Ⓢ in the Part No.

FA: Full voltage adapter

• When pressed, the button is locked in the depressed position, and is reset when either pulled or turned clockwise.

Dimensions

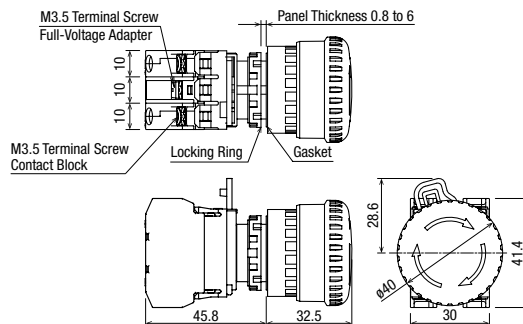

Contact Block Mounting Position



ø22 YW Series Switches & Pilot Lights

Switches & Pilot Lights

Pushbuttons with Plastic Bezel (Pushlock Pull/Turn Reset)

Package Quantity: 1

Shape	Operation	Contact	Contact Block Mounting Position			Part No.	① Button Color Code
			1	2	3		
	Momentary	1NO	NO	—	—	YW1B-M1E10①	B: black G: green R: red S: blue W: white Y: yellow
		1NC	—	—	NC	YW1B-M1E01①	
		2NO	NO	—	NO	YW1B-M1E20①	
		2NC	NC	—	NC	YW1B-M1E02①	
		1NO-1NC	NO	—	NC	YW1B-M1E11①	
		3NO	NO	NO	NO	YW1B-M1E30①	
		3NC	NC	NC	NC	YW1B-M1E03①	
		2NO-1NC	NO	NC	NO	YW1B-M1E21①	
	1NO-2NC	NO	NC	NC	YW1B-M1E12①		
	Maintained	1NO	NO	—	—	YW1B-A1E10①	
		1NC	—	—	NC	YW1B-A1E01①	
		2NO	NO	—	NO	YW1B-A1E20①	
		2NC	NC	—	NC	YW1B-A1E02①	
		1NO-1NC	NO	—	NC	YW1B-A1E11①	
1NO-1NC		NO	—	—	YW1B-M2E10①	B: black G: green R: red S: blue W: white Y: yellow	
Momentary	1NC	—	—	NC	YW1B-M2E01①		
	2NO	NO	—	NO	YW1B-M2E20①		
	2NC	NC	—	NC	YW1B-M2E02①		
	1NO-1NC	NO	—	NC	YW1B-M2E11①		
	Maintained	1NO	NO	—	—		YW1B-A2E10①
		1NC	—	—	NC		YW1B-A2E01①
		2NO	NO	—	NO		YW1B-A2E20①
		2NC	NC	—	NC		YW1B-A2E02①
1NO-1NC		NO	—	NC	YW1B-A2E11①		
1NO-1NC		NO	—	—	YW1B-M4E10①		B: black G: green R: red S: blue W: white Y: yellow
Momentary	1NC	—	—	NC	YW1B-M4E01①		
	2NO	NO	—	NO	YW1B-M4E20①		
	2NC	NC	—	NC	YW1B-M4E02①		
	1NO-1NC	NO	—	NC	YW1B-M4E11①		
Maintained	1NO	NO	—	—	YW1B-A4E10①		
	1NC	—	—	NC	YW1B-A4E01①		
	2NO	NO	—	NO	YW1B-A4E20①		
	2NC	NC	—	NC	YW1B-A4E02①		
	1NO-1NC	NO	—	NC	YW1B-A4E11①		

Note: Specify a button color code in place of ① in the Part No.

Dimensions

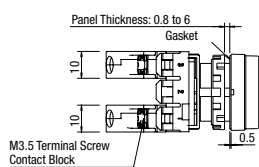

Contact Block Mounting Position

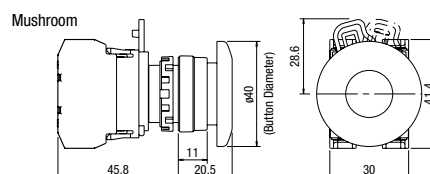
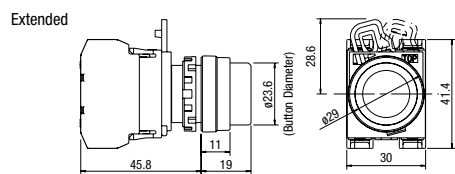
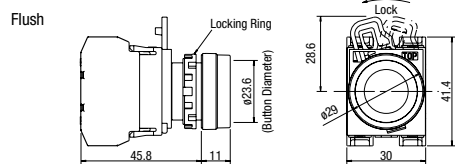

All dimensions in mm.

Download catalogs and CAD from <http://eu.idec.com/downloads>

B-274

ø22 YW Series Switches & Pilot Lights

Pushbuttons with Metal Bezel

Package Quantity: 1

Shape	Operation	Contact	Contact Block Mounting Position			Part No.	① Button Color Code			
			1	2	3					
Flush 	Momentary	1NO	NO	—	—	YW4B-M1E10①	B: black G: green R: red S: blue W: white Y: yellow			
		1NC	—	—	NC	YW4B-M1E01①				
		2NO	NO	—	NO	YW4B-M1E20①				
		2NC	NC	—	NC	YW4B-M1E02①				
		1NO-1NC	NO	—	NC	YW4B-M1E11①				
		3NO	NO	NO	NO	YW4B-M1E30①				
	Maintained	3NC	NC	NC	NC	YW4B-M1E03①				
		2NO-1NC	NO	NC	NO	YW4B-M1E21①				
		1NO-2NC	NO	NC	NC	YW4B-M1E12①				
		1NO	NO	—	—	YW4B-A1E10①				
		1NC	—	—	NC	YW4B-A1E01①				
		2NO	NO	—	NO	YW4B-A1E20①				
Extended 	Momentary	2NC	NC	—	NC	YW4B-M2E02①	B: black G: green R: red S: blue W: white Y: yellow			
		1NO	NO	—	—	YW4B-M2E10①				
		1NC	—	—	NC	YW4B-M2E01①				
		2NO	NO	—	NO	YW4B-M2E20①				
	Maintained	1NO-1NC	NO	—	NC	YW4B-M2E11①				
		1NO	NO	—	—	YW4B-A2E10①				
		1NC	—	—	NC	YW4B-A2E01①				
		2NO	NO	—	NO	YW4B-A2E20①				
		2NC	NC	—	NC	YW4B-A2E02①				
		1NO-1NC	NO	—	NC	YW4B-A2E11①				
		Mushroom ø40mm 	Momentary	1NO	NO	—		—	YW4B-M4E10①	B: black G: green R: red S: blue W: white Y: yellow
				1NC	—	—		NC	YW4B-M4E01①	
2NO	NO			—	NO	YW4B-M4E20①				
Maintained	2NC		NC	—	NC	YW4B-M4E02①				
	1NO-1NC		NO	—	NC	YW4B-M4E11①				
	1NO		NO	—	—	YW4B-A4E10①				
Maintained	1NC	—	—	NC	YW4B-A4E01①					
	2NO	NO	—	NO	YW4B-A4E20①					
	2NC	NC	—	NC	YW4B-A4E02①					
Maintained	1NO-1NC	NO	—	NC	YW4B-A4E11①					

Note: Specify a button color code in place of ① in the Part No.

Dimensions

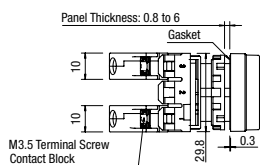

Contact Block Mounting Position



Flush

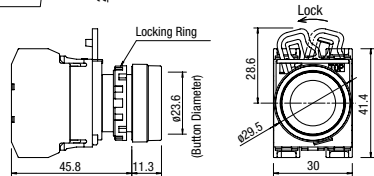

Extended

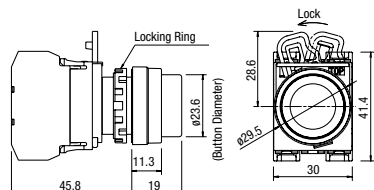

Mushroom

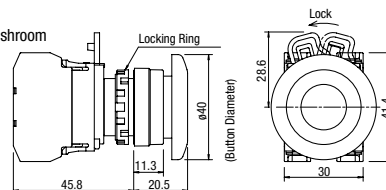

All dimensions in mm.

ø22 YW Series Switches & Pilot Lights

Switches & Pilot Lights

Pilot Lights (Unibody)

Package Quantity: 1

Shape	Lamp	Operating Voltage	Part No.	② Lens Color Code
 Flush Full Voltage	LED	6V AC/DC	YW1P-1UQ2②	A: amber G: green PW: pure white R: red S: blue W: white Y: yellow
		12V AC/DC	YW1P-1UQ3②	
		24V AC/DC	YW1P-1UQ4②	
		100/110V AC	YW1P-1UQH②	
		230/240V AC	YW1P-1UQM3②	
 Flush Marking Full Voltage	LED	6V AC/DC	YW1P-1BUQ2②	
		12V AC/DC	YW1P-1BUQ3②	
		24V AC/DC	YW1P-1BUQ4②	
		100/110V AC	YW1P-1BUQH②	
		230/240V AC	YW1P-1BUQM3②	
 Extended Full Voltage	LED	6V AC/DC	YW1P-2TUQ2②	
		12V AC/DC	YW1P-2TUQ3②	
		24V AC/DC	YW1P-2TUQ4②	
		100/110V AC	YW1P-2TUQH②	
		230/240V AC	YW1P-2TUM3②	
 Dome Full Voltage	LED	6V AC/DC	YW1P-2UQ2②	
		12V AC/DC	YW1P-2UQ3②	
		24V AC/DC	YW1P-2UQ4②	
		100/110V AC	YW1P-2UQH②	
		230/240V AC	YW1P-2UQM3②	

- APEM
- Switches & Pilot Lights
- Control Boxes
- Emergency Stop Switches
- Enabling Switches
- Safety Products
- Explosion Proof
- Terminal Blocks
- Relays & Sockets
- Circuit Protectors
- Power Supplies
- LED Illumination
- Controllers
- Operator Interfaces
- Sensors
- AUTO-ID

Dimensions

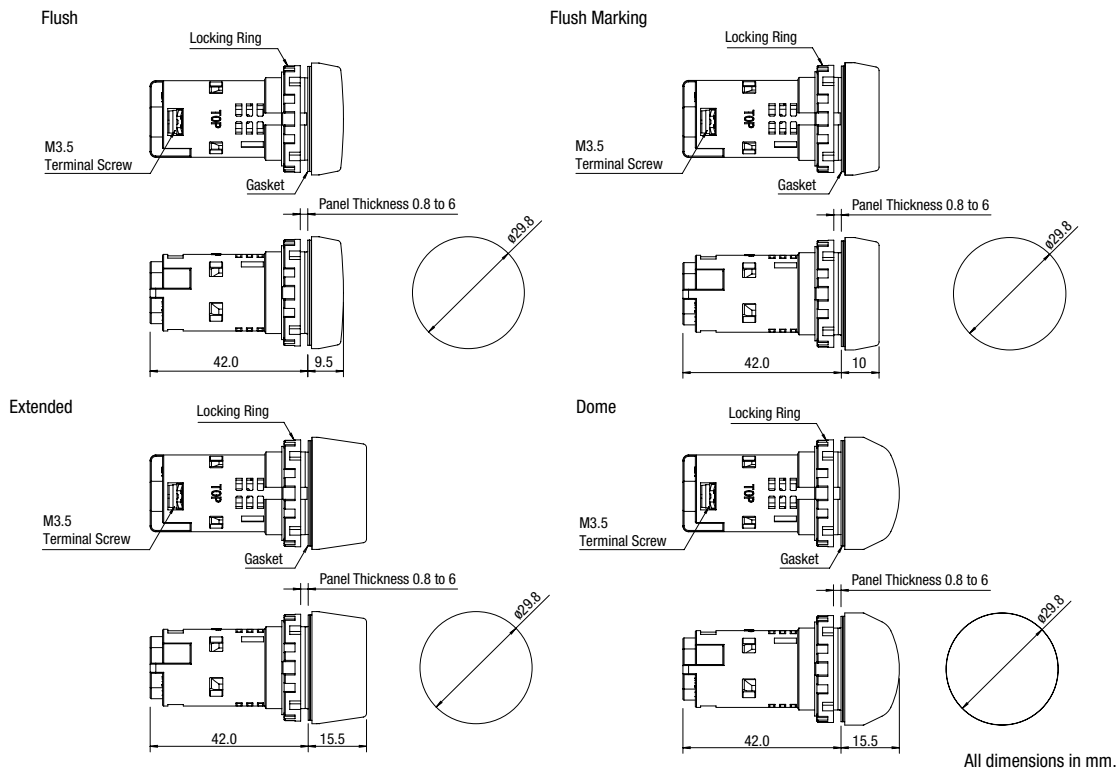

- Flush Silhouette
- ø16
- ø22
- ø30
- Miniature
- Pilot Lights
- HW
- TW
- YW

 Download catalogs and CAD from <http://eu.idec.com/downloads>

B-276

ø22 YW Series Switches & Pilot Lights

Pilot Lights (with Removable Lamp Terminal)

Package Quantity: 1

Shape	Lamp	Operating Voltage	Part No.	② Lens Color Code		
	Flush Full Voltage	Without Lamp	250V AC/DC max.	YW1P-1EQ0②	A (amber), C (clear), G (green), R (red), S (blue), W (white), Y (yellow)	
	LED	Without Lamp	6V AC/DC	YW1P-1EQ2②	A (amber), G (green), PW (pure white), R (red), S (blue), W (white), Y (yellow) Built-in LED lamp: LSED-③②	
			12V AC/DC	YW1P-1EQ3②		
			24V AC/DC	YW1P-1EQ4②		
			110V AC/DC	YW1P-1EQH②		
	Incandescent	Without Lamp	230/240V AC/DC	YW1P-1EQM3②	A (amber), C (clear), G (green), R (red), S (blue), W (white), Y (yellow) Built-in incandescent lamp: LS-T③	
			6V AC/DC	YW1P-1EQ5②		
			12V AC/DC	YW1P-1EQ6②		
	Incandescent	Without Lamp	24V AC/DC	YW1P-1EQ7②	A (amber), C (clear), G (green), R (red), S (blue), W (white), Y (yellow) Built-in incandescent lamp: LS-T③	
			6V AC/DC	YW1P-1EQ5②		
	Flush Transformer	LED	100/110V AC	YW1P-1EH2②	A (amber), G (green), PW (pure white), R (red), S (blue), W (white), Y (yellow) Built-in LED lamp: LSED-6②	
	200/220V AC		YW1P-1EM2②			
	115/120V AC		YW1P-1EH22②			
	230/240V AC		YW1P-1EM42②			
	Incandescent	Without Lamp	100/110V AC	YW1P-1EH5②	A (amber), C (clear), G (green), R (red), S (blue), W (white), Y (yellow) Built-in incandescent lamp: LS-T6	
			200/220V AC	YW1P-1EM5②		
			115/120V AC	YW1P-1EH25②		
			230/240V AC	YW1P-1EM45②		
		Flush Marking Full Voltage	Without Lamp	250V AC/DC max.	YW1P-1BEQ0②	A (amber), G (green), R (red), S (blue), W (white), Y (yellow)
		LED	Without Lamp	6V AC/DC	YW1P-1BEQ2②	A (amber), G (green), PW (pure white), R (red), S (blue), W (white), Y (yellow) Built-in LED lamp: LSED-③②
12V AC/DC				YW1P-1BEQ3②		
24V AC/DC				YW1P-1BEQ4②		
110V AC/DC				YW1P-1BEQH②		
Incandescent		Without Lamp	230/240V AC/DC	YW1P-1BEQM3②	A (amber), G (green), R (red), S (blue), W (white), Y (yellow) Built-in incandescent lamp: LS-T③	
			6V AC/DC	YW1P-1BEQ5②		
			12V AC/DC	YW1P-1BEQ6②		
Incandescent		Without Lamp	24V AC/DC	YW1P-1BEQ7②	A (amber), G (green), R (red), S (blue), W (white), Y (yellow) Built-in incandescent lamp: LS-T③	
			6V AC/DC	YW1P-1BEQ5②		
	Flush Marking Transformer	LED	100/110V AC	YW1P-1BEH2②	A (amber), G (green), PW (pure white), R (red), S (blue), W (white), Y (yellow) Built-in LED lamp: LSED-6②	
	200/220V AC		YW1P-1BEM2②			
	115/120V AC		YW1P-1BEH22②			
	230/240V AC		YW1P-1BEM42②			
	Incandescent	Without Lamp	100/110V AC	YW1P-1BEH5②	A (amber), G (green), R (red), S (blue), W (white), Y (yellow) Built-in incandescent lamp: LS-T6	
			200/220V AC	YW1P-1BEM5②		
			115/120V AC	YW1P-1BEH25②		
			230/240V AC	YW1P-1BEM45②		

Note: Specify a lens color code in place of ② in the Part No.
Clear lenses are used for PW (pure white) illumination of pilot lights.

ø22 YW Series Switches & Pilot Lights

Switches & Pilot Lights

Pilot Lights (with Removable Lamp Terminal)

Package Quantity: 1

Shape	Lamp	Operating Voltage	Part No.	② Lens Color Code	
Extended Full Voltage 	Without Lamp	250V AC/DC max.	YW1P-2TEQ0②	A (amber), C (clear), G (green), R (red), S (blue), W (white), Y (yellow)	
	LED	6V AC/DC	YW1P-2TEQ2②	A (amber), G (green), PW (pure white), R (red), S (blue), W (white), Y (yellow) Built-in LED lamp: LSED-③②	
		12V AC/DC	YW1P-2TEQ3②		
		24V AC/DC	YW1P-2TEQ4②		
		110V AC/DC	YW1P-2TEQH②		
	Incandescent	230/240V AC/DC	YW1P-2TEQM3②	A (amber), C (clear), G (green), R (red), S (blue), W (white), Y (yellow) Built-in incandescent lamp: LS-T③	
		6V AC/DC	YW1P-2TEQ5②		
		12V AC/DC	YW1P-2TEQ6②		
	Extended Transformer 	LED	100/110V AC	YW1P-2TEH2②	A (amber), G (green), PW (pure white), R (red), S (blue), W (white), Y (yellow) Built-in LED lamp: LSED-6②
			200/220V AC	YW1P-2TEM2②	
115/120V AC			YW1P-2TEH22②		
230/240V AC			YW1P-2TEM42②		
Incandescent		100/110V AC	YW1P-2TEH5②	A (amber), C (clear), G (green), R (red), S (blue), W (white), Y (yellow) Built-in incandescent lamp: LS-T6	
		200/220V AC	YW1P-2TEM5②		
		115/120V AC	YW1P-2TEH25②		
		230/240V AC	YW1P-2TEM45②		
Dome Full Voltage 	Without Lamp	250V AC/DC max.	YW1P-2EQ0②	A (amber), C (clear), G (green), R (red), S (blue), W (white), Y (yellow)	
	LED	6V AC/DC	YW1P-2EQ2②	A (amber), G (green), PW (pure white), R (red), S (blue), W (white), Y (yellow) Built-in LED lamp: LSED-③②	
		12V AC/DC	YW1P-2EQ3②		
		24V AC/DC	YW1P-2EQ4②		
		110V AC/DC	YW1P-2EQH②		
	Incandescent	230/240V AC/DC	YW1P-2EQM3②	A (amber), C (clear), G (green), R (red), S (blue), W (white), Y (yellow) Built-in incandescent lamp: LS-T③	
		6V AC/DC	YW1P-2EQ5②		
		12V AC/DC	YW1P-2EQ6②		
	Dome Transformer 	LED	24V AC/DC	YW1P-2EQ7②	A (amber), G (green), PW (pure white), R (red), S (blue), W (white), Y (yellow) Built-in LED lamp: LSED-6②
			100/110V AC	YW1P-2EH2②	
200/220V AC			YW1P-2EM2②		
115/120V AC			YW1P-2EH22②		
Incandescent		230/240V AC	YW1P-2EM42②	A (amber), C (clear), G (green), R (red), S (blue), W (white), Y (yellow) Built-in incandescent lamp: LS-T6	
		100/110V AC	YW1P-2EH5②		
		200/220V AC	YW1P-2EM5②		
		115/120V AC	YW1P-2EH25②		
230/240V AC	YW1P-2EM45②				

Note: Specify a lens color code in place of ② in the Part No.
Clear lenses are used for PW (pure white) illumination of pilot lights.

- APEM
- Switches & Pilot Lights
- Control Boxes
- Emergency Stop Switches
- Enabling Switches
- Safety Products
- Explosion Proof
- Terminal Blocks
- Relays & Sockets
- Circuit Protectors
- Power Supplies
- LED Illumination
- Controllers
- Operator Interfaces
- Sensors
- AUTO-ID

- Flush Silhouette
- ø16
- ø22
- ø30
- Miniature
- Pilot Lights

- HW
- TW
- YW

 Download catalogs and CAD from <http://eu.idec.com/downloads>

B-278

ø22 YW Series Switches & Pilot Lights

Dimensions

All dimensions in mm

Pilot Lights (with Removable Lamp Terminal)

Flush

Full Voltage

Panel Thickness 0.8 to 6

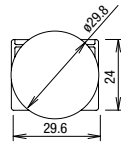
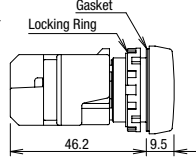
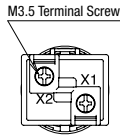
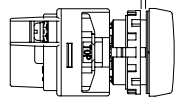

Flush Marking

Full Voltage

Panel Thickness 0.8 to 6

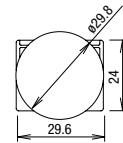
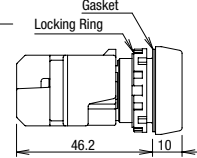
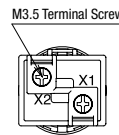
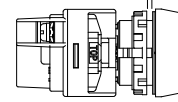

Transformer

Panel Thickness 0.8 to 6

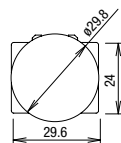
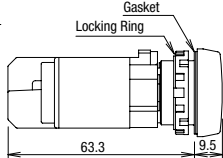
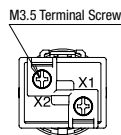
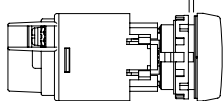

Transformer

Panel Thickness 0.8 to 6

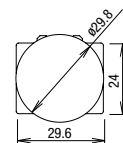
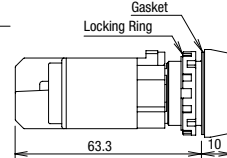
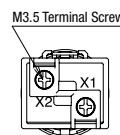
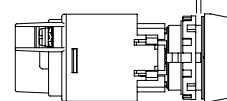

Extended Full Voltage

Panel Thickness 0.8 to 6

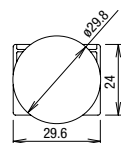
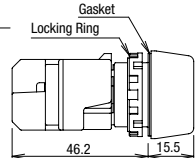
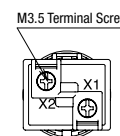
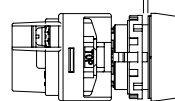

Dome Full Voltage

Panel Thickness 0.8 to 6

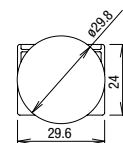
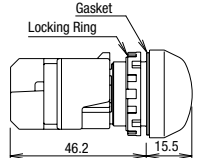
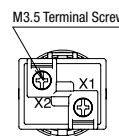
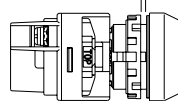

Transformer

Panel Thickness 0.8 to 6

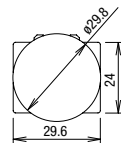
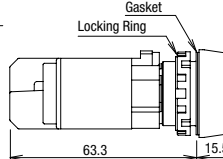
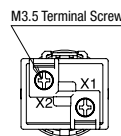
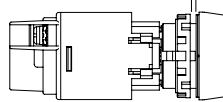

Transformer

Panel Thickness 0.8 to 6

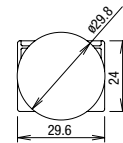
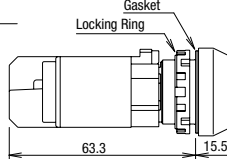
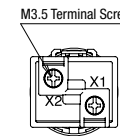
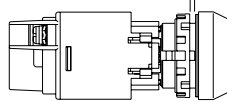

ø22 YW Series Switches & Pilot Lights

Switches & Pilot Lights

Illuminated Pushbuttons with Plastic Bezel

Package Quantity: 1

Shape	Lamp	Operation	Contact	Contact Block Mounting Position			Part No.	Ⓢ Operating Voltage Code	Ⓣ Lens Color Code					
				1	2	3								
	Without Lamp	Momentary	1NO	NO	FA	—	YW1L-M2E10Q0 [Ⓣ]	0: without lamp 250V AC/DC max.	A: amber G: green R: red S: blue W: white Y: yellow					
			1NC	—	FA	NC	YW1L-M2E01Q0 [Ⓣ]							
			2NO	NO	FA	NO	YW1L-M2E20Q0 [Ⓣ]							
			2NC	NC	FA	NC	YW1L-M2E02Q0 [Ⓣ]							
		1NO-1NC	NO	FA	NC	YW1L-M2E11Q0 [Ⓣ]								
		Maintained	1NO	NO	FA	—	YW1L-A2E10Q0 [Ⓣ]			2: 6V AC/DC 3: 12V AC/DC 4: 24V AC/DC H: 110V AC/DC M3: 230/240V AC/DC	A: amber G: green PW: pure white R: red S: blue W: white Y: yellow Built-in LED lamp: LSED-Ⓣ [Ⓣ]			
			1NC	—	FA	NC	YW1L-A2E01Q0 [Ⓣ]							
			2NO	NO	FA	NO	YW1L-A2E20Q0 [Ⓣ]							
			2NC	NC	FA	NC	YW1L-A2E02Q0 [Ⓣ]							
		1NO-1NC	NO	FA	NC	YW1L-A2E11Q0 [Ⓣ]								
		LED	Momentary	1NO	NO	FA	—					YW1L-M2E10Q3 [Ⓣ]	5: 6V AC/DC 6: 12V AC/DC 7: 24V AC/DC	A: amber G: green R: red S: blue W: white Y: yellow Built-in incandescent lamp: LS-T [Ⓣ]
				1NC	—	FA	NC					YW1L-M2E01Q3 [Ⓣ]		
	2NO			NO	FA	NO	YW1L-M2E20Q3 [Ⓣ]							
	2NC			NC	FA	NC	YW1L-M2E02Q3 [Ⓣ]							
	1NO-1NC		NO	FA	NC	YW1L-M2E11Q3 [Ⓣ]								
	Maintained		1NO	NO	FA	—	YW1L-A2E10Q3 [Ⓣ]	0: without lamp 250V AC/DC max.	A: amber G: green R: red S: blue W: white Y: yellow					
			1NC	—	FA	NC	YW1L-A2E01Q3 [Ⓣ]							
			2NO	NO	FA	NO	YW1L-A2E20Q3 [Ⓣ]							
			2NC	NC	FA	NC	YW1L-A2E02Q3 [Ⓣ]							
	1NO-1NC		NO	FA	NC	YW1L-A2E11Q3 [Ⓣ]								
	Incandescent		Momentary	1NO	NO	FA	—			YW1L-MF2E10Q0 [Ⓣ]	5: 6V AC/DC 6: 12V AC/DC 7: 24V AC/DC	A: amber G: green R: red S: blue W: white Y: yellow Built-in incandescent lamp: LS-T [Ⓣ]		
				1NC	—	FA	NC			YW1L-MF2E01Q0 [Ⓣ]				
		2NO		NO	FA	NO	YW1L-MF2E20Q0 [Ⓣ]							
		2NC		NC	FA	NC	YW1L-MF2E02Q0 [Ⓣ]							
1NO-1NC		NO	FA	NC	YW1L-MF2E11Q0 [Ⓣ]									
Maintained		1NO	NO	FA	—	YW1L-AF2E10Q0 [Ⓣ]	2: 6V AC/DC 3: 12V AC/DC 4: 24V AC/DC H: 110V AC/DC M3: 230/240V AC/DC			A: amber G: green PW: pure white R: red S: blue W: white Y: yellow Built-in LED lamp: LSED-Ⓣ [Ⓣ]				
		1NC	—	FA	NC	YW1L-AF2E01Q0 [Ⓣ]								
		2NO	NO	FA	NO	YW1L-AF2E20Q0 [Ⓣ]								
		2NC	NC	FA	NC	YW1L-AF2E02Q0 [Ⓣ]								
1NO-1NC		NO	FA	NC	YW1L-AF2E11Q0 [Ⓣ]									
LED		Momentary	1NO	NO	FA	—		YW1L-MF2E10Q3 [Ⓣ]	5: 6V AC/DC 6: 12V AC/DC 7: 24V AC/DC				A: amber G: green R: red S: blue W: white Y: yellow Built-in incandescent lamp: LS-T [Ⓣ]	
			1NC	—	FA	NC		YW1L-MF2E01Q3 [Ⓣ]						
	2NO		NO	FA	NO	YW1L-MF2E20Q3 [Ⓣ]								
	2NC		NC	FA	NC	YW1L-MF2E02Q3 [Ⓣ]								
	1NO-1NC	NO	FA	NC	YW1L-MF2E11Q3 [Ⓣ]									
	Maintained	1NO	NO	FA	—	YW1L-AF2E10Q3 [Ⓣ]		0: without lamp 250V AC/DC max.			A: amber G: green R: red S: blue W: white Y: yellow			
		1NC	—	FA	NC	YW1L-AF2E01Q3 [Ⓣ]								
		2NO	NO	FA	NO	YW1L-AF2E20Q3 [Ⓣ]								
		2NC	NC	FA	NC	YW1L-AF2E02Q3 [Ⓣ]								
	1NO-1NC	NO	FA	NC	YW1L-AF2E11Q3 [Ⓣ]									
	Incandescent	Momentary	1NO	NO	FA	—	YW1L-MF2E10Q3 [Ⓣ]			5: 6V AC/DC 6: 12V AC/DC 7: 24V AC/DC		A: amber G: green R: red S: blue W: white Y: yellow Built-in incandescent lamp: LS-T [Ⓣ]		
			1NC	—	FA	NC	YW1L-MF2E01Q3 [Ⓣ]							
2NO			NO	FA	NO	YW1L-MF2E20Q3 [Ⓣ]								
2NC			NC	FA	NC	YW1L-MF2E02Q3 [Ⓣ]								
1NO-1NC		NO	FA	NC	YW1L-MF2E11Q3 [Ⓣ]									
Maintained		1NO	NO	FA	—	YW1L-AF2E10Q3 [Ⓣ]	0: without lamp 250V AC/DC max.		A: amber G: green R: red S: blue W: white Y: yellow					
		1NC	—	FA	NC	YW1L-AF2E01Q3 [Ⓣ]								
		2NO	NO	FA	NO	YW1L-AF2E20Q3 [Ⓣ]								
		2NC	NC	FA	NC	YW1L-AF2E02Q3 [Ⓣ]								
1NO-1NC		NO	FA	NC	YW1L-AF2E11Q3 [Ⓣ]									

Note: Specify a lens color code in place of Ⓣ in the Part No.

Specify an operating voltage code in place of Ⓢ in the Part No.

FA: Full voltage adapter



Download catalogs and CAD from <http://eu.idec.com/downloads>

B-280

- APEM
- Switches & Pilot Lights
- Control Boxes
- Emergency Stop Switches
- Enabling Switches
- Safety Products
- Explosion Proof
- Terminal Blocks
- Relays & Sockets
- Circuit Protectors
- Power Supplies
- LED Illumination
- Controllers
- Operator Interfaces
- Sensors
- AUTO-ID
- Flush Silhouette
- ø16
- ø22
- ø30
- Miniature
- Pilot Lights
- HW
- TW
- YW

ø22 YW Series Switches & Pilot Lights

Illuminated Pushbuttons with Plastic Bezel

Package Quantity: 1

Shape	Lamp	Operation	Contact	Contact Block Mounting Position			Part No.	③ Operating Voltage Code	② Lens Color Code			
				1	2	3						
	Without Lamp	Momentary	1NO	NO	FA	—	YW1L-M4E10Q0②	0: without lamp 250V AC/DC max.	A: amber G: green R: red S: blue W: white Y: yellow			
			1NC	—	FA	NC	YW1L-M4E01Q0②					
			2NO	NO	FA	NO	YW1L-M4E20Q0②					
			2NC	NC	FA	NC	YW1L-M4E02Q0②					
			1NO-1NC	NO	FA	NC	YW1L-M4E11Q0②					
			1NO	NO	FA	—	YW1L-A4E10Q0②					
		1NC	—	FA	NC	YW1L-A4E01Q0②						
		2NO	NO	FA	NO	YW1L-A4E20Q0②						
		2NC	NC	FA	NC	YW1L-A4E02Q0②						
		1NO-1NC	NO	FA	NC	YW1L-A4E11Q0②						
		LED	Momentary	1NO	NO	FA	—			YW1L-M4E10Q③②	2: 6V AC/DC 3: 12V AC/DC 4: 24V AC/DC H: 110V AC/DC M3: 230/240V AC/DC	A: amber G: green PW: pure white R: red S: blue W: white Y: yellow Built-in LED lamp: LSED-③②
				1NC	—	FA	NC			YW1L-M4E01Q③②		
	2NO			NO	FA	NO	YW1L-M4E20Q③②					
	2NC		NC	FA	NC	YW1L-M4E02Q③②						
	1NO-1NC		NO	FA	NC	YW1L-M4E11Q③②						
	1NO		NO	FA	—	YW1L-A4E10Q③②						
	Maintained	1NC	—	FA	NC	YW1L-A4E01Q③②						
		2NO	NO	FA	NO	YW1L-A4E20Q③②						
		2NC	NC	FA	NC	YW1L-A4E02Q③②						
	Incandescent	Momentary	1NO	NO	FA	—	YW1L-M4E10Q③②	5: 6V AC/DC 6: 12V AC/DC 7: 24V AC/DC	A: amber G: green R: red S: blue W: white Y: yellow Built-in incandescent lamp: LS-T③			
			1NC	—	FA	NC	YW1L-M4E01Q③②					
			2NO	NO	FA	NO	YW1L-M4E20Q③②					
		2NC	NC	FA	NC	YW1L-M4E02Q③②						
		1NO-1NC	NO	FA	NC	YW1L-M4E11Q③②						
1NO		NO	FA	—	YW1L-A4E10Q③②							
Maintained	1NC	—	FA	NC	YW1L-A4E01Q③②							
	2NO	NO	FA	NO	YW1L-A4E20Q③②							
	2NC	NC	FA	NC	YW1L-A4E02Q③②							
1NO-1NC	NO	FA	NC	YW1L-A4E11Q③②								

ø16

Note: Specify a lens color code in place of ② in the Part No.

FA: Full voltage adapter

ø22

Specify an operating voltage code in place of ③ in the Part No.

ø30

Dimensions

(Illuminated Pushbuttons with Plastic Bezel)

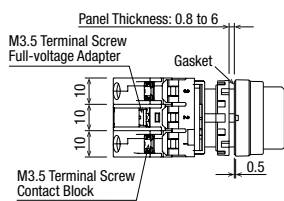

Contact Block Mounting Position



Extended

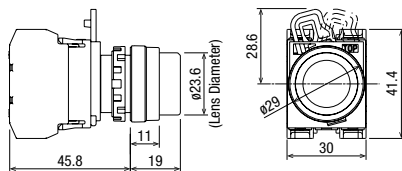

Mushroom

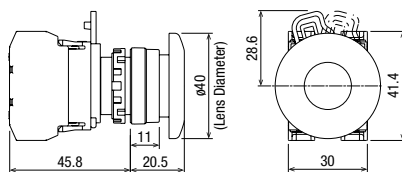

Extended with Full Shroud

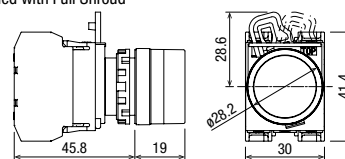

All dimensions in mm.

B-281



For more information, visit <http://eu.idec.com>

ø22 YW Series Switches & Pilot Lights

Switches & Pilot Lights

Illuminated Pushbuttons with Metal Bezel

Package Quantity: 1

Shape	Lamp	Operation	Contact	Contact Block Mounting Position			Part No.	Ⓢ Operating Voltage Code	Ⓜ Lens Color Code
				1	2	3			
	Without Lamp	Momentary	1NO	NO	FA	—	YW4L-M2E10Q0②	0: without lamp 250V AC/DC max.	A: amber G: green R: red S: blue W: white Y: yellow
			1NC	—	FA	NC	YW4L-M2E01Q0②		
			2NO	NO	FA	NO	YW4L-M2E20Q0②		
			2NC	NC	FA	NC	YW4L-M2E02Q0②		
		Maintained	1NO-1NC	NO	FA	NC	YW4L-M2E11Q0②		
			1NO	NO	FA	—	YW4L-A2E10Q0②		
			1NC	—	FA	NC	YW4L-A2E01Q0②		
			2NO	NO	FA	NO	YW4L-A2E20Q0②		
	LED	Momentary	2NC	NC	FA	NC	YW4L-A2E02Q0②	2: 6V AC/DC 3: 12V AC/DC 4: 24V AC/DC H: 110V AC/DC M3: 230/240V AC/DC	A: amber G: green PW: pure white R: red S: blue W: white Y: yellow Built-in LED lamp: LSED-③②
			1NO-1NC	NO	FA	NC	YW4L-M2E11Q0③②		
			1NO	NO	FA	—	YW4L-A2E10Q0③②		
			1NC	—	FA	NC	YW4L-A2E01Q0③②		
		Maintained	2NO	NO	FA	NO	YW4L-A2E20Q0③②		
			2NC	NC	FA	NC	YW4L-A2E02Q0③②		
			1NO-1NC	NO	FA	NC	YW4L-A2E11Q0③②		
			1NO	NO	FA	—	YW4L-M2E10Q0③②		
	Incandescent	Momentary	1NC	—	FA	NC	YW4L-M2E01Q0③②	5: 6V AC/DC 6: 12V AC/DC 7: 24V AC/DC	A: amber G: green R: red S: blue W: white Y: yellow Built-in incandescent lamp: LS-T③
			2NO	NO	FA	NO	YW4L-M2E20Q0③②		
			2NC	NC	FA	NC	YW4L-M2E02Q0③②		
			1NO-1NC	NO	FA	NC	YW4L-M2E11Q0③②		
		Maintained	1NO	NO	FA	—	YW4L-A2E10Q0③②		
			1NC	—	FA	NC	YW4L-A2E01Q0③②		
			2NO	NO	FA	NO	YW4L-A2E20Q0③②		
			2NC	NC	FA	NC	YW4L-A2E02Q0③②		
	Without Lamp	Momentary	1NO	NO	FA	—	YW4L-MF2E10Q0②	0: without lamp 250V AC/DC max.	A: amber G: green R: red S: blue W: white Y: yellow
			1NC	—	FA	NC	YW4L-MF2E01Q0②		
			2NO	NO	FA	NO	YW4L-MF2E20Q0②		
			2NC	NC	FA	NC	YW4L-MF2E02Q0②		
		Maintained	1NO-1NC	NO	FA	NC	YW4L-MF2E11Q0②		
			1NO	NO	FA	—	YW4L-AF2E10Q0②		
			1NC	—	FA	NC	YW4L-AF2E01Q0②		
			2NO	NO	FA	NO	YW4L-AF2E20Q0②		
	LED	Momentary	2NC	NC	FA	NC	YW4L-AF2E02Q0②	2: 6V AC/DC 3: 12V AC/DC 4: 24V AC/DC H: 110V AC/DC M3: 230/240V AC/DC	A: amber G: green PW: pure white R: red S: blue W: white Y: yellow Built-in LED lamp: LSED-③②
			1NO-1NC	NO	FA	NC	YW4L-MF2E11Q0③②		
			1NO	NO	FA	—	YW4L-AF2E10Q0③②		
			1NC	—	FA	NC	YW4L-AF2E01Q0③②		
		Maintained	2NO	NO	FA	NO	YW4L-AF2E20Q0③②		
			2NC	NC	FA	NC	YW4L-AF2E02Q0③②		
			1NO-1NC	NO	FA	NC	YW4L-AF2E11Q0③②		
			1NO	NO	FA	—	YW4L-MF2E10Q0③②		
	Incandescent	Momentary	1NC	—	FA	NC	YW4L-MF2E01Q0③②	5: 6V AC/DC 6: 12V AC/DC 7: 24V AC/DC	A: amber G: green R: red S: blue W: white Y: yellow Built-in incandescent lamp: LS-T③
			2NO	NO	FA	NO	YW4L-MF2E20Q0③②		
			2NC	NC	FA	NC	YW4L-MF2E02Q0③②		
			1NO-1NC	NO	FA	NC	YW4L-MF2E11Q0③②		
		Maintained	1NO	NO	FA	—	YW4L-AF2E10Q0③②		
			1NC	—	FA	NC	YW4L-AF2E01Q0③②		
			2NO	NO	FA	NO	YW4L-AF2E20Q0③②		
			2NC	NC	FA	NC	YW4L-AF2E02Q0③②		
Incandescent	Momentary	1NO-1NC	NO	FA	NC	YW4L-AF2E11Q0③②	5: 6V AC/DC 6: 12V AC/DC 7: 24V AC/DC	A: amber G: green R: red S: blue W: white Y: yellow Built-in incandescent lamp: LS-T③	
		1NO	NO	FA	—	YW4L-MF2E10Q0③②			
		1NC	—	FA	NC	YW4L-MF2E01Q0③②			
		2NO	NO	FA	NO	YW4L-MF2E20Q0③②			
Maintained	Momentary	2NC	NC	FA	NC	YW4L-MF2E02Q0③②	5: 6V AC/DC 6: 12V AC/DC 7: 24V AC/DC	A: amber G: green R: red S: blue W: white Y: yellow Built-in incandescent lamp: LS-T③	
		1NO-1NC	NO	FA	NC	YW4L-MF2E11Q0③②			
		1NO	NO	FA	—	YW4L-AF2E10Q0③②			
		1NC	—	FA	NC	YW4L-AF2E01Q0③②			
Maintained	Momentary	2NO	NO	FA	NO	YW4L-AF2E20Q0③②	5: 6V AC/DC 6: 12V AC/DC 7: 24V AC/DC	A: amber G: green R: red S: blue W: white Y: yellow Built-in incandescent lamp: LS-T③	
		2NC	NC	FA	NC	YW4L-AF2E02Q0③②			
		1NO-1NC	NO	FA	NC	YW4L-AF2E11Q0③②			
		1NO	NO	FA	—	YW4L-MF2E10Q0③②			

Note: Specify a lens color code in place of ② in the Part No.
Specify an operating voltage code in place of ③ in the Part No.

FA: Full voltage adapter

- APEM
- Switches & Pilot Lights
- Control Boxes
- Emergency Stop Switches
- Enabling Switches
- Safety Products
- Explosion Proof
- Terminal Blocks
- Relays & Sockets
- Circuit Protectors
- Power Supplies
- LED Illumination
- Controllers
- Operator Interfaces
- Sensors
- AUTO-ID
- Flush Silhouette
- ø16
- ø22
- ø30
- Miniature
- Pilot Lights
- HW
- TW
- YW



Download catalogs and CAD from <http://eu.idec.com/downloads>

B-282

ø22 YW Series Switches & Pilot Lights

Illuminated Pushbuttons with Metal Bezel

Package Quantity: 1

Style	Lamp	Operation	Contact	Contact Block Mounting Position			Part No.	③ Operating Voltage Code	② Lens Color Code
				1	2	3			
ø40mm Mushroom	Without Lamp	Momentary	1NO	NO	FA	—	YW4L-M4E10Q②	0: without lamp 250V AC/DC max.	A: amber G: green R: red S: blue W: white Y: yellow
			1NC	—	FA	NC	YW4L-M4E01Q②		
			2NO	NO	FA	NO	YW4L-M4E20Q②		
			2NC	NC	FA	NC	YW4L-M4E02Q②		
			1NO-1NC	NO	FA	NC	YW4L-M4E11Q②		
			1NO-1NC	NO	FA	NC	YW4L-M4E11Q②		
		Maintained	1NO	NO	FA	—	YW4L-A4E10Q②		
			1NC	—	FA	NC	YW4L-A4E01Q②		
			2NO	NO	FA	NO	YW4L-A4E20Q②		
			2NC	NC	FA	NC	YW4L-A4E02Q②		
			1NO-1NC	NO	FA	NC	YW4L-A4E11Q②		
			1NO-1NC	NO	FA	NC	YW4L-A4E11Q②		
	LED	Momentary	1NO	NO	FA	—	YW4L-M4E10Q③②	2: 6V AC/DC 3: 12V AC/DC 4: 24V AC/DC H: 110V AC/DC M3: 230/240V AC/DC	A: amber G: green PW: pure white R: red S: blue W: white Y: yellow Built-in LED lamp: LSED-③②
			1NC	—	FA	NC	YW4L-M4E01Q③②		
			2NO	NO	FA	NO	YW4L-M4E20Q③②		
			2NC	NC	FA	NC	YW4L-M4E02Q③②		
			1NO-1NC	NO	FA	NC	YW4L-M4E11Q③②		
			1NO-1NC	NO	FA	NC	YW4L-M4E11Q③②		
		Maintained	1NO	NO	FA	—	YW4L-A4E10Q③②		
			1NC	—	FA	NC	YW4L-A4E01Q③②		
			2NO	NO	FA	NO	YW4L-A4E20Q③②		
			2NC	NC	FA	NC	YW4L-A4E02Q③②		
			1NO-1NC	NO	FA	NC	YW4L-A4E11Q③②		
			1NO-1NC	NO	FA	NC	YW4L-A4E11Q③②		
Incandescent	Momentary	1NO	NO	FA	—	YW4L-M4E10Q③②	5: 6V AC/DC 6: 12V AC/DC 7: 24V AC/DC	A: amber G: green R: red S: blue W: white Y: yellow Built-in incandescent lamp: LS-T③	
		1NC	—	FA	NC	YW4L-M4E01Q③②			
		2NO	NO	FA	NO	YW4L-M4E20Q③②			
		2NC	NC	FA	NC	YW4L-M4E02Q③②			
		1NO-1NC	NO	FA	NC	YW4L-M4E11Q③②			
		1NO-1NC	NO	FA	NC	YW4L-M4E11Q③②			
	Maintained	1NO	NO	FA	—	YW4L-A4E10Q③②			
		1NC	—	FA	NC	YW4L-A4E01Q③②			
		2NO	NO	FA	NO	YW4L-A4E20Q③②			
		2NC	NC	FA	NC	YW4L-A4E02Q③②			
		1NO-1NC	NO	FA	NC	YW4L-A4E11Q③②			
		1NO-1NC	NO	FA	NC	YW4L-A4E11Q③②			

Note: Specify a lens color code in place of ② in the Part No.

FA: Full voltage adapter

Specify an operating voltage code in place of ③ in the Part No.

Dimensions (Illuminated Pushbutton with Metal Bezel)

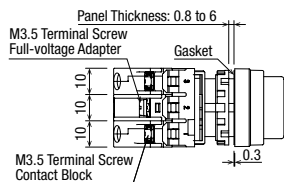

Contact Block Mounting Position



Extended

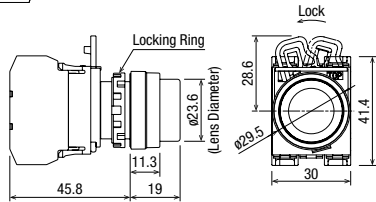

Mushroom

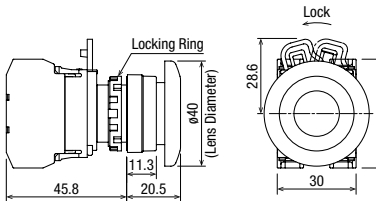

Extended with Full Shroud

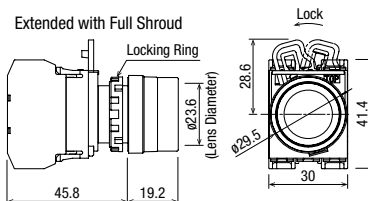



All dimensions in mm.

ø22 YW Series Switches & Pilot Lights

Switches & Pilot Lights

Selector Switches with Plastic Bezel

Package Quantity: 1

Shape				Knob							
No. of Positions	Contact Configuration	Contact Block Mounting Position	Operator Position			Maintained	Spring Return from Right	—	—		
			L	R	—						
90° 2-Position 	1NO (10)	1	NO		●		YW1S-2E10	YW1S-21E10	—	—	
		2									
		3									
	1NC (01)	1						YW1S-2E01	YW1S-21E01	—	—
		2									
		3	NC	●							
	2NO (20)	1	NO			●		YW1S-2E20	YW1S-21E20	—	—
		2									
		3	NO			●					
	2NC (02)	1	NC	●				YW1S-2E02	YW1S-21E02	—	—
		2									
		3	NC	●							
	1NO-1NC (11)	1	NO			●		YW1S-2E11	YW1S-21E11	—	—
		2									
		3	NC	●							
	3NO (30)	1	NO			●		YW1S-2E30	YW1S-21E30	—	—
		2	NO			●					
		3	NO			●					
3NC (03)	1	NC	●				YW1S-2E03	YW1S-21E03	—	—	
	2	NC	●								
	3	NC	●								
2NO-1NC (21)	1	NO			●		YW1S-2E21	YW1S-21E21	—	—	
	2	NC	●								
	3	NO			●						
1NO-2NC (12)	1	NO			●		YW1S-2E12	YW1S-21E12	—	—	
	2	NC	●								
	3	NC	●								
No. of Positions	Contact Configuration	Contact Block Mounting Position	Operator Position			Maintained	Spring Return from Right	Spring Return from Left	Spring Return Two-Way		
			L	C	R						
45° 3-Position 	2NO (20)	1	NO	●			YW1S-3E20	YW1S-31E20	YW1S-32E20	YW1S-33E20	
		2									
		3	NO				●				
	2NO (20N1)	1	NO	●				YW1S-3E20N1	YW1S-31E20N1	YW1S-32E20N1	YW1S-33E20N1
		2	NO			●					
		3	NO			●					
	2NC (02)	1	NC				■	YW1S-3E02	YW1S-31E02	YW1S-32E02	YW1S-33E02
		2									
		3	NC				■				
	2NC (02N1)	1	NC				■	YW1S-3E02N1	YW1S-31E02N1	YW1S-32E02N1	YW1S-33E02N1
		2	NC				■				
		3	NC				■				
	1NO-1NC (11)	1	NO	●				YW1S-3E11	YW1S-31E11	YW1S-32E11	YW1S-33E11
		2									
		3	NC				■				
	1NO-1NC (11N1)	1	NO	●				YW1S-3E11N1	YW1S-31E11N1	YW1S-32E11N1	YW1S-33E11N1
		2									
		3	NO			●					
	1NO-1NC (11N2)	1	NO	●				YW1S-3E11N2	YW1S-31E11N2	YW1S-32E11N2	YW1S-33E11N2
		2	NC			●					
		3									
	1NO-1NC (11N3)	1						YW1S-3E11N3	YW1S-31E11N3	YW1S-32E11N3	YW1S-33E11N3
		2	NC			●					
		3	NO			●					
1NO-1NC (11N4)	1						YW1S-3E11N4	YW1S-31E11N4	YW1S-32E11N4	YW1S-33E11N4	
	2	NO	●			●					
	3	NC				■					
3NO (30)	1	NO	●				YW1S-3E30	YW1S-31E30	YW1S-32E30	YW1S-33E30	
	2	NO	●								
	3	NO			●						
3NC (03)	1	NC				■	YW1S-3E03	YW1S-31E03	YW1S-32E03	YW1S-33E03	
	2	NC				■					
	3	NC				■					
2NO-1NC (21)	1	NO	●				YW1S-3E21	YW1S-31E21	YW1S-32E21	YW1S-33E21	
	2	NC			●						
	3	NO			●						
1NO-2NC (12)	1	NO	●				YW1S-3E12	YW1S-31E12	YW1S-32E12	YW1S-33E12	
	2	NO	●								
	3	NC				■					

 Download catalogs and CAD from <http://eu.idec.com/downloads>

B-284

ø22 YW Series Switches & Pilot Lights

Selector Switches with Metal Bezel

Package Quantity: 1

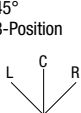
Shape				Knob							
No. of Positions	Contact Configuration	Contact Block Mounting Position	Operator Position			Maintained	Spring Return from Right	—	—		
			L	R	—						
90° 2-Position 	1NO (10)	1	NO		●		YW4S-2E10	YW4S-21E10	—	—	
		2									
		3									
	1NC (01)	1						YW4S-2E01	YW4S-21E01	—	—
		2									
		3	NC	●							
	2NO (20)	1	NO			●		YW4S-2E20	YW4S-21E20	—	—
		2					●				
		3	NO			●					
	2NC (02)	1	NC	●				YW4S-2E02	YW4S-21E02	—	—
		2									
		3	NC	●							
	1NO-1NC (11)	1	NO			●		YW4S-2E11	YW4S-21E11	—	—
		2									
		3	NC	●							
	3NO (30)	1	NO			●		YW4S-2E30	YW4S-21E30	—	—
		2	NO			●					
		3	NO			●					
3NC (03)	1	NC	●				YW4S-2E03	YW4S-21E03	—	—	
	2	NC	●								
	3	NC	●								
2NO-1NC (21)	1	NO			●		YW4S-2E21	YW4S-21E21	—	—	
	2	NC	●								
	3	NO			●						
1NO-2NC (12)	1	NO			●		YW4S-2E12	YW4S-21E12	—	—	
	2	NC	●								
	3	NC	●								
45° 3-Position 	2NO (20)	1	NO	●			YW4S-3E20	YW4S-31E20	YW4S-32E20	YW4S-33E20	
		2									
		3	NO			●					
	2NO (20N1)	1	NO	●				YW4S-3E20N1	YW4S-31E20N1	YW4S-32E20N1	YW4S-33E20N1
		2	NO			●					
		3	NO			●					
	2NC (02)	1	NC	●				YW4S-3E02	YW4S-31E02	YW4S-32E02	YW4S-33E02
		2									
		3	NC	●							
	2NC (02N1)	1	NC	●				YW4S-3E02N1	YW4S-31E02N1	YW4S-32E02N1	YW4S-33E02N1
		2	NC	●							
		3	NC	●							
	1NO-1NC (11)	1	NO			●		YW4S-3E11	YW4S-31E11	YW4S-32E11	YW4S-33E11
		2									
		3	NC	●							
	1NO-1NC (11N1)	1	NC	●				YW4S-3E11N1	YW4S-31E11N1	YW4S-32E11N1	YW4S-33E11N1
		2									
		3	NO			●					
	1NO-1NC (11N2)	1	NO	●				YW4S-3E11N2	YW4S-31E11N2	YW4S-32E11N2	YW4S-33E11N2
		2	NC			●					
		3									
	1NO-1NC (11N3)	1						YW4S-3E11N3	YW4S-31E11N3	YW4S-32E11N3	YW4S-33E11N3
		2	NC			●					
		3	NO			●					
	1NO-1NC (11N4)	1						YW4S-3E11N4	YW4S-31E11N4	YW4S-32E11N4	YW4S-33E11N4
		2	NO	●							
		3	NC	●							
	3NO (30)	1	NO	●				YW4S-3E30	YW4S-31E30	YW4S-32E30	YW4S-33E30
		2	NO	●							
		3	NO	●							
3NC (03)	1	NC	●				YW4S-3E03	YW4S-31E03	YW4S-32E03	YW4S-33E03	
	2	NC	●								
	3	NC	●								
2NO-1NC (21)	1	NO			●		YW4S-3E21	YW4S-31E21	YW4S-32E21	YW4S-33E21	
	2	NC	●								
	3	NO			●						
1NO-2NC (12)	1	NC	●				YW4S-3E12	YW4S-31E12	YW4S-32E12	YW4S-33E12	
	2	NO	●								
	3	NC	●								

B-285

For more information, visit <http://eu.idec.com>

ø22 YW Series Switches & Pilot Lights

Switches & Pilot Lights

Dimensions

All dimensions in mm

Selector Switch with Plastic Bezel

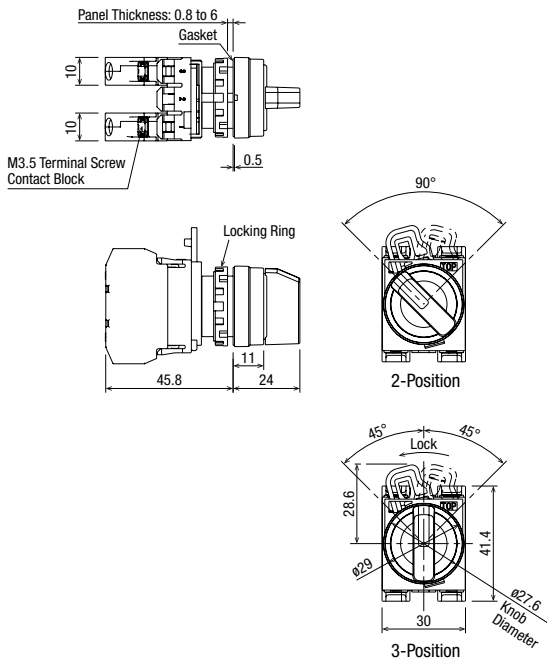

Selector Switch with Metal Bezel

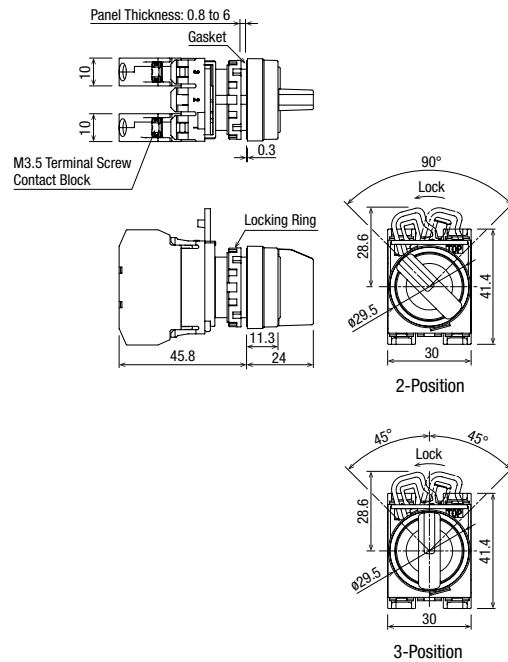

Contact Block Mounting Position

Selector Switch with Plastic Bezel



Selector Switch with Metal Bezel



APEM

Switches & Pilot Lights

Control Boxes

Emergency Stop Switches
Enabling Switches

Safety Products

Explosion Proof

Terminal Blocks

Relays & Sockets

Circuit Protectors

Power Supplies

LED Illumination

Controllers

Operator Interfaces

Sensors

AUTO-ID

Flush Silhouette

ø16

ø22

ø30

Miniature

Pilot Lights

HW

TW

YW





 Download catalogs and CAD from <http://eu.idec.com/downloads>

B-286

ø22 YW Series Switches & Pilot Lights

Key Selector Switches (90° 2-Position)

Package Quantity: 1

No. of Positions	Contact Configuration	Contact Block Mounting Position		Operator Position		Part No.		
				L	R	Plastic Bezel	Metal Bezel	
								
90° 2-position Maintained 	1NO (10)	1	NO		●	YW1K-2AE10	YW4K-2AE10	
		2						
		3						
	1NC (01)	1					YW1K-2AE01	YW4K-2AE01
		2						
		3	NC	●				
	2NO (20)	1	NO			●	YW1K-2AE20	YW4K-2AE20
		2						
		3	NO			●		
	2NC (02)	1	NC	●			YW1K-2AE02	YW4K-2AE02
		2						
		3	NC	●				
	1NO-1NC (11)	1	NO			●	YW1K-2AE11	YW4K-2AE11
		2						
		3	NC	●				
	3NO (30)	1	NO			●	YW1K-2AE30	YW4K-2AE30
		2	NO			●		
		3	NO			●		
	3NC (03)	1	NC	●			YW1K-2AE03	YW4K-2AE03
		2	NC	●				
		3	NC	●				
	2NO-1NC (21)	1	NO			●	YW1K-2AE21	YW4K-2AE21
		2	NC	●				
		3	NO			●		
1NO-2NC (12)	1	NO			●	YW1K-2AE12	YW4K-2AE12	
	2	NC	●					
	3	NC	●					
90° 2-position Spring Return from Right 	1NO (10)	1	NO		●	YW1K-21BE10	YW4K-21BE10	
		2						
		3						
	1NC (01)	1					YW1K-21BE01	YW4K-21BE01
		2						
		3	NC	●				
	2NO (20)	1	NO			●	YW1K-21BE20	YW4K-21BE20
		2						
		3	NO			●		
	2NC (02)	1	NC	●			YW1K-21BE02	YW4K-21BE02
		2						
		3	NC	●				
	1NO-1NC (11)	1	NO			●	YW1K-21BE11	YW4K-21BE11
		2						
		3	NC	●				
	3NO (30)	1	NO			●	YW1K-21BE30	YW4K-21BE30
		2	NO			●		
		3	NO			●		
	3NC (03)	1	NC	●			YW1K-21BE03	YW4K-21BE03
		2	NC	●				
		3	NC	●				
	2NO-1NC (21)	1	NO			●	YW1K-21BE21	YW4K-21BE21
		2	NC	●				
		3	NO			●		
1NO-2NC (12)	1	NO			●	YW1K-21BE12	YW4K-21BE12	
	2	NC	●					
	3	NC	●					

- On the spring-returned types, the key can be removed only from the maintained position. On the maintained types, the key can be removed from every position. Key retained positions are also available. See Part No. Development shown on **B-288**.
- Each key selector switch is supplied with two identical keys.

B-287



For more information, visit <http://eu.idec.com>

ø22 YW Series Switches & Pilot Lights

Switches & Pilot Lights

Key Selector Switches (45° 3-Position)

Package Quantity: 1

No. of Positions	Contact Configuration	Contact Block Mounting Position		Operator Position			Part No.		
				L	C	R	Plastic Bezel	Metal Bezel	
									
45° 3-position Maintained 	2NO (20)	1	NO	●			YW1K-3AE20	YW4K-3AE20	
		2							
		3	NO			●			
	2NO (20N1)	1						YW1K-3AE20N1	YW4K-3AE20N1
		2	NO	●		●			
		3	NO			●			
	2NC (02)	1	NC		■			YW1K-3AE02	YW4K-3AE02
		2			■				
		3	NC	■					
	2NC (02N1)	1				●		YW1K-3AE02N1	YW4K-3AE02N1
		2	NC		■				
		3	NC	■					
	1NO-1NC (11)	1	NO	●				YW1K-3AE11	YW4K-3AE11
		2							
		3	NC	■					
	1NO-1NC (11N1)	1	NC			■		YW1K-3AE11N1	YW4K-3AE11N1
		2							
		3	NO				●		
	1NO-1NC (11N2)	1	NO	●				YW1K-3AE11N2	YW4K-3AE11N2
		2	NC			●			
		3							
	1NO-1NC (11N3)	1						YW1K-3AE11N3	YW4K-3AE11N3
		2	NC			●			
		3	NO				●		
1NO-1NC (11N4)	1						YW1K-3AE11N4	YW4K-3AE11N4	
	2	NO	●			●			
	3	NC	■						
3NO (30)	1	NO	●				YW1K-3AE30	YW4K-3AE30	
	2	NO	●			●			
	3	NO				●			
3NC (03)	1	NC		■			YW1K-3AE03	YW4K-3AE03	
	2	NC			●				
	3	NC	■						
2NO-1NC (21)	1	NO	●				YW1K-3AE21	YW4K-3AE21	
	2	NC			●				
	3	NO				●			
1NO-2NC (12)	1	NC		■			YW1K-3AE12	YW4K-3AE12	
	2	NO	●			●			
	3	NC	■						

- On the maintained types, the key can be removed from every position. Key retained positions are also available. See Part No. Development below.
- Each key selector switch is supplied with two identical keys.

Part No. Development

YW1K-2 A E21

- Key removal position code
- 2-position
 - A: Removable in all positions
 - B: Removable in left only
 - C: Removable in right only
- 3-position
 - A: Removable in all positions
 - B: Removable in left and center
 - C: Removable in right and center
 - D: Removable in center only
 - E: Removable in right and left
 - G: Removable in left only
 - H: Removable in right only

Contact Block Mounting Position

Contact Block Mounting Position

1 2 3

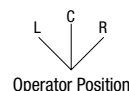



 Download catalogs and CAD from <http://eu.idec.com/downloads>

B-288

ø22 YW Series Switches & Pilot Lights

Key Selector Switches (45° 3-Position)

Package Quantity: 1

No. of Positions	Contact Configuration	Contact Block Mounting Position		Operator Position			Part No.		
				L	C	R	Plastic Bezel	Metal Bezel	
									
<div style="display: flex; align-items: center;"> <div style="margin-right: 10px;"> <p>45° 3-position Spring Return from Right</p>  </div> <div style="font-size: small;"> <p>Control Boxes</p> <p>Emergency Stop Switches</p> <p>Enabling Switches</p> <p>Safety Products</p> <p>Explosion Proof</p> <p>Terminal Blocks</p> <p>Relays & Sockets</p> <p>Circuit Protectors</p> <p>Power Supplies</p> <p>LED Illumination</p> <p>Controllers</p> <p>Operator Interfaces</p> <p>Sensors</p> <p>AUTO-ID</p> <p>Flush Silhouette</p> <p>ø16</p> <p>ø22</p> <p>ø30</p> <p>Miniature</p> <p>Pilot Lights</p> <p>HW</p> </div> </div>	2NO (20)	1	NO	●			YW1K-31BE20	YW4K-31BE20	
		2							
		3	NO			●			
	2NO (20N1)	1						YW1K-31BE20N1	YW4K-31BE20N1
		2	NO	●		●			
		3	NO			●			
	2NC (02)	1	NC		■			YW1K-31BE02	YW4K-31BE02
		2							
		3	NC	■					
	2NC (02N1)	1				●		YW1K-31BE02N1	YW4K-31BE02N1
		2	NC	■					
		3	NC	■					
	1NO-1NC (11)	1	NO	●				YW1K-31BE11	YW4K-31BE11
		2							
		3	NC	■					
	1NO-1NC (11N1)	1	NC		■			YW1K-31BE11N1	YW4K-31BE11N1
		2							
		3	NO			●			
	1NO-1NC (11N2)	1	NO	●				YW1K-31BE11N2	YW4K-31BE11N2
		2	NC		●				
		3							
	1NO-1NC (11N3)	1						YW1K-31BE11N3	YW4K-31BE11N3
		2	NC		●				
		3	NO			●			
1NO-1NC (11N4)	1	NO	●		●		YW1K-31BE11N4	YW4K-31BE11N4	
	2	NO	●		●				
	3	NC	■						
3NO (30)	1	NO	●				YW1K-31BE30	YW4K-31BE30	
	2	NO	●		●				
	3	NO			●				
3NC (03)	1	NC		■			YW1K-31BE03	YW4K-31BE03	
	2	NC		●					
	3	NC	■						
2NO-1NC (21)	1	NO	●				YW1K-31BE21	YW4K-31BE21	
	2	NC		●					
	3	NO			●				
1NO-2NC (12)	1	NC		■			YW1K-31BE12	YW4K-31BE12	
	2	NO	●		●				
	3	NC	■						

TW • On the spring-returned types, the key can be removed only from the maintained position. Key retained positions are also available. See Part No. Development shown on B-288.



YW • Each key selector switch is supplied with two identical keys.

ø22 YW Series Switches & Pilot Lights

Switches & Pilot Lights

Key Selector Switches (45° 3-Position)

Package Quantity: 1

No. of Positions	Contact Configuration	Contact Block Mounting Position		Operator Position			Part No.		
				L	C	R	Plastic Bezel	Metal Bezel	
									
45° 3-position Spring Return from Left 	2NO (20)	1	NO	●			YW1K-32CE20	YW4K-32CE20	
		2							
		3	NO			●			
	2NO (20N1)	1						YW1K-32CE20N1	YW4K-32CE20N1
		2	NO	●		●			
		3	NO			●			
	2NC (02)	1	NC		■			YW1K-32CE02	YW4K-32CE02
		2							
		3	NC	■					
	2NC (02N1)	1				●		YW1K-32CE02N1	YW4K-32CE02N1
		2	NC						
		3	NC	■					
	1NO-1NC (11)	1	NO	●				YW1K-32CE11	YW4K-32CE11
		2							
		3	NC	■					
	1NO-1NC (11N1)	1	NC			■		YW1K-32CE11N1	YW4K-32CE11N1
		2							
		3	NO			●			
	1NO-1NC (11N2)	1	NO	●				YW1K-32CE11N2	YW4K-32CE11N2
		2	NC		●				
		3							
	1NO-1NC (11N3)	1						YW1K-32CE11N3	YW4K-32CE11N3
		2	NC		●				
		3	NO			●			
1NO-1NC (11N4)	1						YW1K-32CE11N4	YW4K-32CE11N4	
	2	NO	●		●				
	3	NC	■						
3NO (30)	1	NO	●				YW1K-32CE30	YW4K-32CE30	
	2	NO	●		●				
	3	NO			●				
3NC (03)	1	NC			■		YW1K-32CE03	YW4K-32CE03	
	2	NC		●					
	3	NC	■						
2NO-1NC (21)	1	NO	●				YW1K-32CE21	YW4K-32CE21	
	2	NC		●					
	3	NO			●				
1NO-2NC (12)	1	NC			■		YW1K-32CE12	YW4K-32CE12	
	2	NO	●		●				
	3	NC	■						

- On the spring-returned types, the key can be removed only from the maintained position. Key retained positions are also available. See Part No. Development shown on B-288.
- Each key selector switch is supplied with two identical keys.

APEM

Switches & Pilot Lights

Control Boxes

Emergency Stop Switches

Enabling Switches

Safety Products

Explosion Proof

Terminal Blocks

Relays & Sockets

Circuit Protectors

Power Supplies

LED Illumination

Controllers

Operator Interfaces

Sensors

AUTO-ID

Flush Silhouette

ø16

ø22

ø30

Miniature

Pilot Lights

HW

TW

YW



 Download catalogs and CAD from <http://eu.idec.com/downloads>

B-290

ø22 YW Series Switches & Pilot Lights

Key Selector Switches (45° 3-Position)

Package Quantity: 1

No. of Positions	Contact Configuration	Contact Block Mounting Position		Operator Position			Part No.		
				L	C	R	Plastic Bezel	Metal Bezel	
									
45° 3-position Spring Return Two-way 	2NO (20)	1	NO	●			YW1K-33DE20	YW4K-33DE20	
		2							
		3	NO			●			
	2NO (20N1)	1						YW1K-33DE20N1	YW4K-33DE20N1
		2	NO	●		●			
		3	NO			●			
	2NC (02)	1	NC		■			YW1K-33DE02	YW4K-33DE02
		2			■				
		3	NC	■					
	2NC (02N1)	1				●		YW1K-33DE02N1	YW4K-33DE02N1
		2	NC		■				
		3	NC	■					
	1NO-1NC (11)	1	NO	●				YW1K-33DE11	YW4K-33DE11
		2							
		3	NC	■					
	1NO-1NC (11N1)	1	NC		■			YW1K-33DE11N1	YW4K-33DE11N1
		2							
		3	NO			●			
	1NO-1NC (11N2)	1	NO	●				YW1K-33DE11N2	YW4K-33DE11N2
		2	NC			●			
		3							
	1NO-1NC (11N3)	1						YW1K-33DE11N3	YW4K-33DE11N3
		2	NC			●			
		3	NO				●		
1NO-1NC (11N4)	1						YW1K-33DE11N4	YW4K-33DE11N4	
	2	NO	●		●				
	3	NC	■						
3NO (30)	1	NO	●				YW1K-33DE30	YW4K-33DE30	
	2	NO	●		●				
	3	NO			●				
3NC (03)	1	NC		■			YW1K-33DE03	YW4K-33DE03	
	2	NC			●				
	3	NC	■						
2NO-1NC (21)	1	NO	●				YW1K-33DE21	YW4K-33DE21	
	2	NC			●				
	3	NO				●			
1NO-2NC (12)	1	NC		■			YW1K-33DE12	YW4K-33DE12	
	2	NO	●		●				
	3	NC	■						

TW • On the spring-returned types, the key can be removed only from the maintained position. Key retained positions are also available. See Part No. Development shown on B-288.

YW • Each key selector switch is supplied with two identical keys.

ø22 YW Series Switches & Pilot Lights

Switches & Pilot Lights

Dimensions

All dimensions in mm

Plastic Bezel

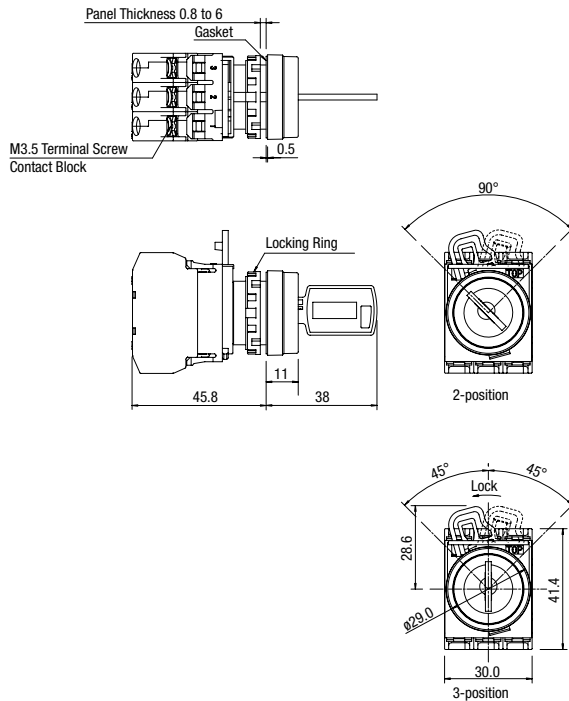

Metal Bezel

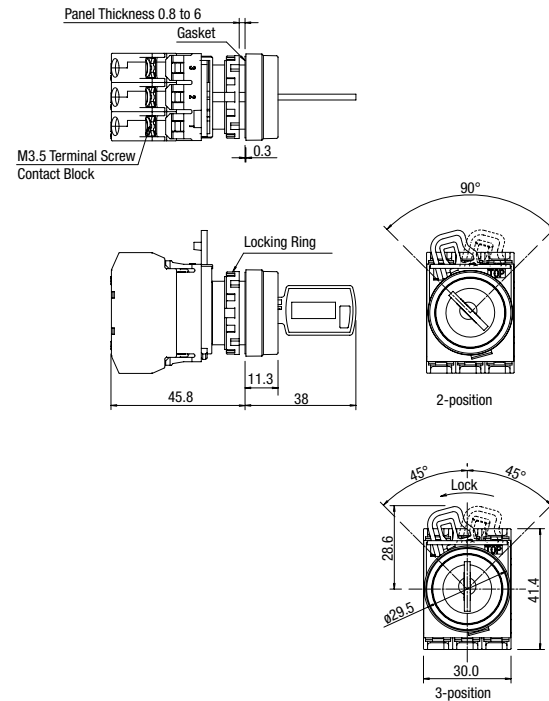

Contact Block Mounting Position

Plastic Bezel

Contact Block Mounting Position



Metal Bezel

Contact Block Mounting Position



APEM

Switches & Pilot Lights

Control Boxes

Emergency Stop Switches

Enabling Switches

Safety Products

Explosion Proof

Terminal Blocks

Relays & Sockets

Circuit Protectors

Power Supplies

LED Illumination

Controllers

Operator Interfaces

Sensors

AUTO-ID

Flush Silhouette

ø16

ø22

ø30

Miniature

Pilot Lights

HW

TW









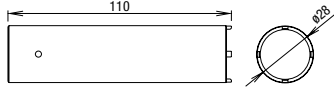

YW

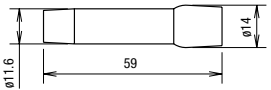
Download catalogs and CAD from <http://eu.idec.com/downloads>

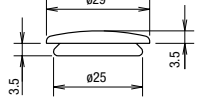
B-292

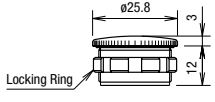
ø22 YW Series Switches & Pilot Lights

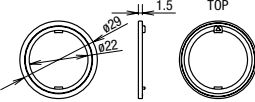
Accessories

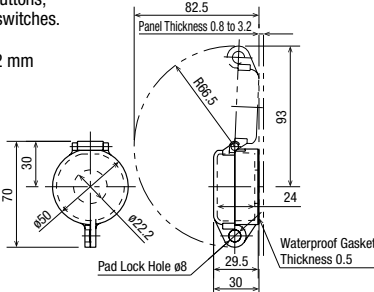
Name & Shape	Part No.	Description & Dimensions (mm)	Package Quantity
 <p>APEM</p>	MW9Z-T1	<p>Metallic tool used to tighten the plastic locking ring when installing the YW series in a panel.</p> 	1
 <p>Control Boxes Emergency Stop Switches Enabling Switches</p>	OR-55	<p>Made of rubber. Used for replacing lamps.</p> 	1
 <p>Safety Products Explosion Proof Terminal Blocks</p>	OB-31PN05	<p>Used for plugging unused mounting holes in the panel. Color: Black</p> 	5
 <p>Relays & Sockets Circuit Protectors Power Supplies LED Illumination</p>	LW9Z-BM	<p>Used for plugging unused mounting holes in the panel. Weight: Approx. 18g</p> 	1
 <p>Controllers Operator Interfaces Sensors AUTO-ID</p>	HW9Z-RLPN10	<p>Prevents rotation of switches in panel. Mainly used with selector switches when no nameplate is used. With waterproof gasket (IP65). Made of plastic (black). Applicable panel thickness: 1.2 to 4.5 mm</p> 	10
 <p>Flush Silhouette ø16 ø22 ø30 Miniature Pilot Lights</p>	HW9Z-KL1	<p>Plastic hinged cover to protect pushbuttons, illuminated pushbuttons, or selector switches. Degree of protection: IP65. Applicable panel thickness: 0.8 to 3.2 mm</p> 	1

HW







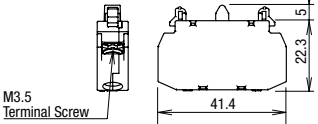

TW

YW

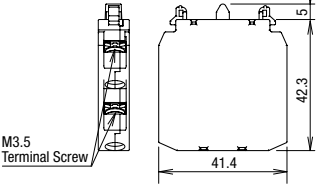
ø22 YW Series Switches & Pilot Lights

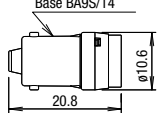
Switches & Pilot Lights

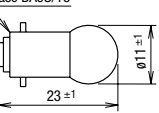
Maintenance Parts

Name & Shape	Part No.	Description & Dimensions (mm)			Package Quantity
	YW-E10	Contact: 1NO	Color: blue		10
	YW-E01	Contact: 1NC	Color: reddish purple		
	YW-EW20	Contact: 2NO	Color: blue		10
	YW-EW02	Contact: 2NC	Color: reddish purple		
	YW-EW11	Contact: 1NO-1NC	Color: blue and reddish purple		
	LSED-6②	6V AC/DC	Specify a color code in place of ② in the Part No.: A (amber), G (green), PW (pure white), R (red), S (blue), Y (yellow) See B-271 for applicable units and rated current. Note: Yellow LED lamps are used for white illumination of pilot lights and illuminated pushbuttons.		1
	LSED-1②	12V AC/DC			
	LSED-2②	24V AC/DC			
	LSED-H②	110V AC/DC			
	LSED-M3②	230/240V AC/DC			
	LS-T6P	6.3V, 1W	One pack contains 100 incandescent lamps.		100
	LS-T8P	18V, 1W			
	LS-T3P	30V, 1W			
	YW9Z-SK00PN02				2

- APEM
- Switches & Pilot Lights
- Control Boxes
- Emergency Stop Switches
- Enabling Switches
- Safety Products
- Explosion Proof
- Terminal Blocks
- Relays & Sockets
- Circuit Protectors
- Power Supplies
- LED Illumination
- Controllers
- Operator Interfaces
- Sensors
- AUTO-ID
- Flush Silhouette

- ø16
- ø22
- ø30
- Miniature
- Pilot Lights
- HW
- TW

YW









 Download catalogs and CAD from <http://eu.idec.com/downloads>

B-294

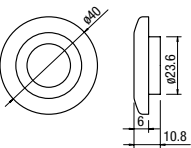
ø22 YW Series Switches & Pilot Lights

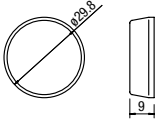
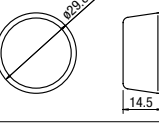
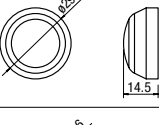
Maintenance Parts

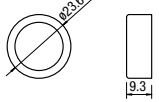
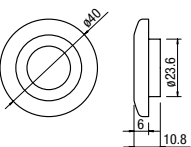
Buttons, Lenses, and Marking Plates

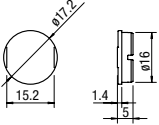
Name	Style	Part No.	① ② Color Code	Dimensions (mm)	Package Quantity
Button (for pushbuttons)  	Extended	YW9Z-B12①PN10	B: black G: green R: red S: blue W: white Y: yellow		10
	Mushroom ø40mm	YW9Z-B14①PN10			
Lens (for pilot lights)    	Flush	YW9Z-PL11②PN10	A: amber C: clear G: green R: red S: blue W: white Y: yellow		10
	Flush Marking	YW9Z-PL11B②PN10	A: amber C: clear G: green R: red S: blue Y: yellow		10
	Extended	YW9Z-PL12T②PN10	A: amber C: clear G: green R: red S: blue W: white Y: yellow		10
	Dome	YW9Z-PL12②PN10	A: amber C: clear G: green R: red S: blue W: white Y: yellow		10
	Flush Silhouette	—	—	—	—
Lens (for illuminated pushbuttons)  	Extended	YW9Z-L12②PN10	A: amber C: clear G: green R: red S: blue Y: yellow		10
	Mushroom ø40mm	YW9Z-L14②PN10			
Marking Plate (for pilot lights) 	—	YW9Z-PP12PN10	—		10
Marking Plate (for illuminated pushbuttons) 	—	YW9Z-P12PN10	—		10

ø22 YW Series Switches & Pilot Lights

Switches & Pilot Lights

Nameplates

HWAM, HWAQ, HWAS, and HWAV

Name	Legend	Material	Part No.	Ordering No.	Package Quantity	Dimensions (mm)
HWAM	Order marking plate separately.	Plastic (black) 1.5 mm thick	HWAM	HWAM	1	
				HWAMPN10	10	
HWAQ	Order marking plate separately.	Plastic (black) 1.5 mm thick	HWAQ	HWAQ	1	
				HWAQPN10	10	
HWAQ	Blank	Plastic (black) 1.5 mm thick	HWAS-0	HWAS-0	1	
				HWAS-0PN10	10	
HWAV	Blank	Plastic (yellow) 1.5 mm thick	HWAV-0	HWAV-0	1	
	EMERGENCY STOP			HWAV-27	HWAV-27	

Making Plate

Description	Material	Part No.	Ordering No.	Package Quantity	Dimensions (mm)
HWNP	Aluminum (black) 1.0 mm thick	HWNP-*	HWNP-*	1	White legend on black background.
			HWNP-*PN10	10	

• Specify a legend code in place of * in the Ordering No.

Legends

Code	Legend
0	(blank)
1	ON
2	OFF
3	START
4	STOP
31	OFF-ON
35	HAND-AUTO
53	HAND-OFF-AUTO

• Installing the marking plate on a nameplate

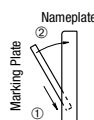

• To remove the marking plate, insert the flat screwdriver between the marking plate and nameplate.

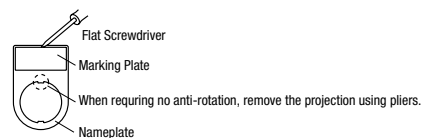

Note: When using an nameplate, the mounting panel thickness is decreased by 1.5 mm.







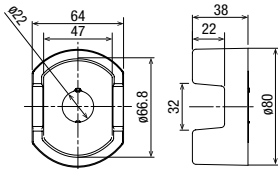

Download catalogs and CAD from <http://eu.idec.com/downloads>

B-296

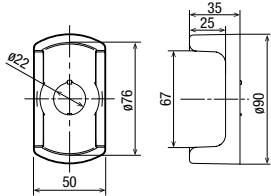
ø22 YW Series Switches & Pilot Lights

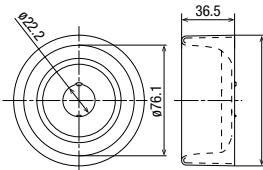
Switch Guards

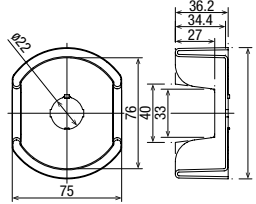
Package Quantity: 1

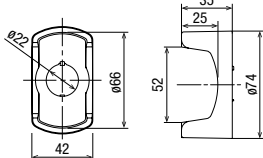
Part No. & Shape (mm)	Dimensions	Part No. & Shape	Dimensions (mm)
 <p>HW9Z-KG1 EMO Switch Guard SEMI S2 compliant (Note 1)</p>		 <p>HW9Z-KG4 EMO Switch Guard SEMI S2 compliant (Note 2) SEMATECH compliant (Note 3)</p>	
 <p>HW9Z-KG2 EMO Switch Guard SEMI S2 compliant (Note 1) SEMATECH compliant (Note 3)</p>		 <p>HW9Z-KG5 EMO Switch Guard SEMI S2 compliant (Note 2) SEMATECH compliant (Note 3)</p>	
 <p>HW9Z-KG3 EMO Switch Guard SEMI S2 compliant (Note 2)</p>		<p>Material: Polyamide (PA6) Color: Yellow, Munsell 2.5Y 8/10 equivalent Degree of protection: IP65</p> <ul style="list-style-type: none"> Degree of protection IP65 applies to the combination of an emergency stop switch and an EMO switch guard. <p>Note 1: SEMI S2-0703 12.5.1 compliant. Note 2: The combination of IDEC's emergency stop switches and EMO switch guards are approved by TÜV Rheinland for compliance with SEMI S2 standard. Note 3: SEMATECH Application Guide for SEMI S2-93, 12.4.c. compliant.</p>	

Transformer

Din Rail Mount Transformer For 6V

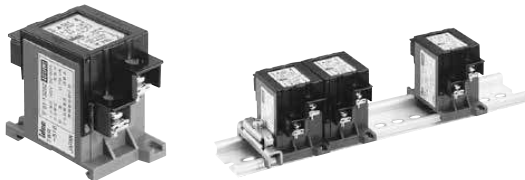

Dimensions (mm)

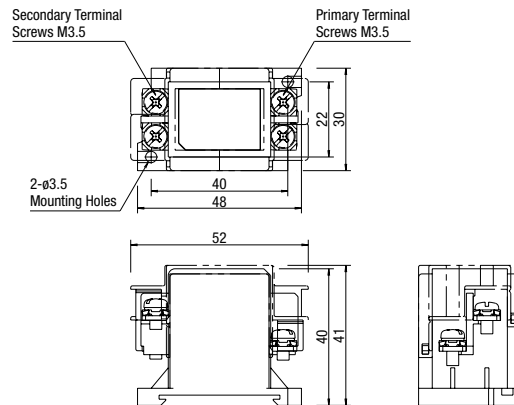

Note: Finger-safe terminal cover is supplied with the transformer.

Primary Voltage (50/60 Hz)	Part No.	Applicable Lamp Rating
110V AC	TWR516	One full voltage type illuminated unit containing LED lamp LSED-6 (6V AC/DC) or incandescent lamp LS-T6 (6.3V)
115V AC	TWR5116	
120V AC	TWR5126	
220V AC	TWR526	
230V AC	TWR5236	
240V AC	TWR5246	
380V AC	TWR5386	
440V AC	TWR546	
480V AC	TWR5486	

Accessories

When ordering, specify the Ordering No.

Shape	Material	Part No.	Ordering No.	Package Quantity	Dimensions (mm)
DIN 35 mm Rail	Aluminum	BAA1000	BAA1000PN10	10	Length: 1000 mm Weight: 200g approx.
	Steel	BAP1000	BAP1000PN10	10	Length: 1000 mm Weight: 320g approx.
End Clip	Metal (zinc-plated steel)	BNL6	BNL6PN10	10	Applicable rail: AA1000, BAP1000 Weight: 15g approx.

• See H-071 for DIN rail products.

⚠ Safety Precautions

- Turn off the power to the YW series before starting installation, removal, wiring, maintenance, and inspection of the products. Failure to turn power off may cause electrical shocks or fire hazard.
- To avoid burning your hand, use the lamp holder tool when replacing lamps.

- For wiring, use wires of a proper size to meet the voltage and current requirements. Tighten the M3.5 terminal screws to a tightening torque of 1.0 N-m. Failure to tighten the terminal screws may cause overheating and fire.

Instructions

Panel Mounting

- Remove the contact block from the operator (for pilot lights, remove the transformer or full voltage unit from the pilot light). Remove the locking ring from the operator. Insert the operator into the panel cut-out from the front, tighten the locking ring from the back, then install the contact block to the operator.

Removing and Installing the Contact Block

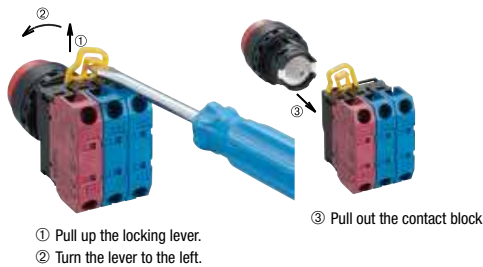

1. To remove the operator from the contact block, pull up the locking lever and turn it to the left. Then the operator can be pulled out.
2. To reinstall, place the TOP marking on the operator and the TOP marking on the contact block mounting adapter in the same direction, and insert the operator into the contact block mounting adapter. Then turn the locking lever to the right.

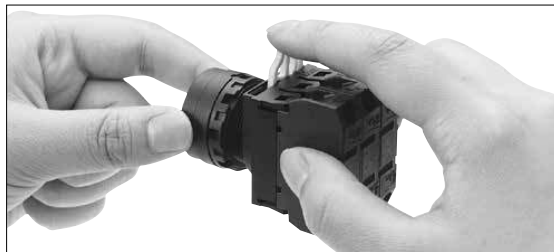

Removing and Installing the Transformer

1. Insert a flat screwdriver (5 mm wide at maximum) into the latch hole on the transformer unit as shown in the photo below, and disengage the latch. Then pull out the operator.
2. To reinstall, place the TOP marking on the operator and the latch in the same direction, and push the operator into the transformer.

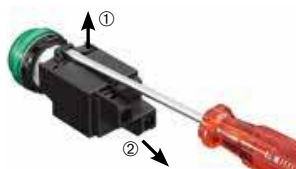

Removing the Full Voltage Unit

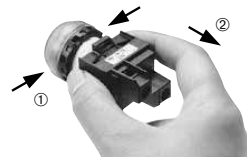

1. To remove the full voltage unit, squeeze the full voltage unit from both sides to disengage the latch as shown, and pull it out. Like the transformer unit, the full voltage unit can also be pulled out by inserting a flat screwdriver into the latch hole as shown.
2. To reinstall, place the TOP markings on the operator and the latch on the full voltage unit in the same direction, and insert the operator into the full voltage unit.

Notes for Panel Mounting

1. Use the optional locking ring wrench (MW9Z-T1) to mount the operator onto a panel. Tightening torque must not exceed 2.0 N-m. Do not use pliers. Excessive tightening will damage the locking ring.
2. For contact blocks and transformers housing LED and incandescent lamps, make sure not to press the lamps too hard, otherwise the lamp socket may be damaged.

Insertion Order of Lens and Marking Plate

Illuminated Pushbutton

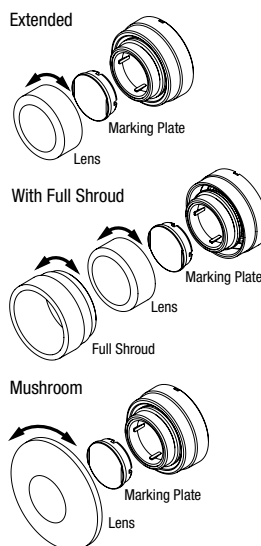

Pilot Light

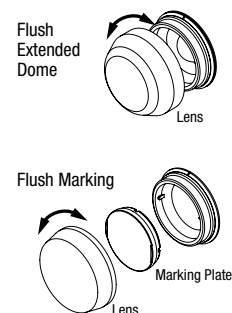

APEM

Switches & Pilot Lights

Control Boxes

Emergency Stop Switches
Enabling Switches

Safety Products

Explosion Proof

Terminal Blocks

Relays & Sockets

Circuit Protectors

Power Supplies

LED Illumination

Controllers

Operator Interfaces

Sensors

AUTO-ID

Flush Silhouette

ø16

ø22

ø30

Miniature

Pilot Lights

HW

TW

YW

 Download catalogs and CAD from <http://eu.idec.com/downloads>

B-298

ø22 YW Series Switches & Pilot Lights

Instructions

Marking

For YW series pilot lights and illuminated pushbuttons, legends and symbols can be engraved on built-in marking plates, or printed mylar film can be inserted under the lens for labeling purposes. Mylar film is not supplied with the YW series and must be supplied by the end user.

APEM

Built-in Marking Plate and Marking Film Size

Unit	Pilot Light	Illuminated Pushbutton
Built-in Marking Plate		
	Engraving depth: 0.5 mm maximum Marking plate material: White acrylic	
Applicable Marking Film		
	0.1-mm-thick × 2 sheets or 0.2-mm-thick × 1 sheet Film material: Mylar (recommended) Note: Marking film is not supplied with the pilot light or illuminated pushbutton.	

Replacement (LED and incandescent lamps)

Lamps can be replaced using the lamp holder tool (OR-55) from the front of the panel, or by removing the contact block from the operator unit.

Removing the Lamp from the Front of the Panel



To remove, gently insert the lamp holder tool onto the lamp head. Then push slightly, and turn the lamp holder tool to the left.

Installing the Lamp from the Front of the Panel

- To install, insert the lamp head into the lamp holder tool, and hold the lamp as shown in the figure below.

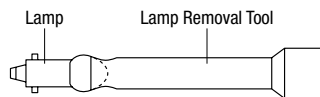

- Place the pins on the lamp base to the grooves in the lamp socket. Insert the lamp and turn it to the right.

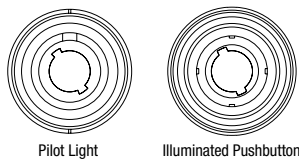

Note: LED lamps in unibody pilot lights cannot be replaced.

Removing Contact Blocks and Full Voltage Adapters

Insert a flat screwdriver between the latch and contact block mounting adapter, and disengage the latch.

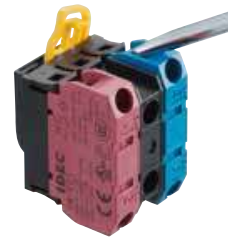

Make sure to remove the lamp and contact blocks before removing the full voltage adapter.

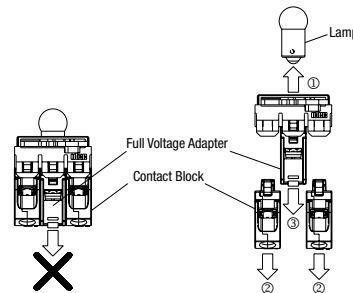

Tightening Torque for Terminal Screws

Tighten terminal screws to a torque of 1.0 N·m.

Anti-rotation Ring and Mounting Panel

Turn the TOP marking on the operator and the ▲ mark on the anti-rotation ring to the recess on the mounting panel.

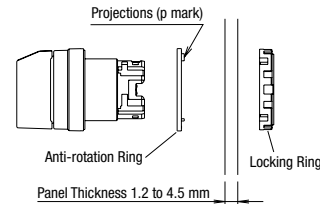

Mounting Panel Thickness

The mounting panel must be 0.8 to 6.0 mm in thickness. When optional accessories are added, the applicable panel thickness changes as shown below.

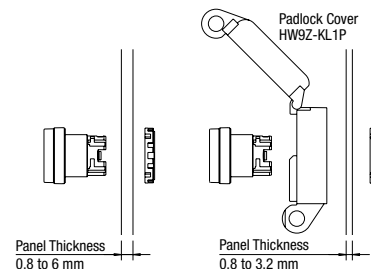

Contact Bounce

When pressing or turning the operator, the NC and NO contacts will bounce. When designing a control circuit, take the contact bounce time into consideration (reference value: 20 ms).

Instructions

Precautions for Noise

When using the unibody pilot light in an environment where it is subjected to noise, connect a noise suppressor across terminals X1 and X2 as shown below.

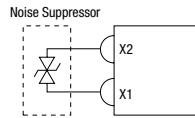

Key Selector Switch

Before operation, ensure that the key is inserted into the key hole completely. Operating the key selector switch with a loose key will cause damage to the key selector switch.

LED Illumination

LED lamps consist of semiconductors. If the applied voltage exceeds the rated voltage, LED elements deteriorate due to overheat, resulting in significant decrease in brightness, hue change, or failure of lighting. Also, if extraneous noise, transient voltage, or transient current is applied to the circuit, similar effects will be caused. When using LED lamps, observe the following instructions.

Rated Voltage

The LED illuminated units are rated at 6V, 12V, 24V, 110V, or 230/240V AC/DC, and can be used within $\pm 10\%$ the rated voltage of either AC or DC, except the 230/240V AC/DC types can be used on 250V AC/DC maximum.

DC Power

- Switching power supply**
Regulated voltage from a switching power supply is best suited. Make sure to use within the rated voltage of the LED lamp.
- Rechargeable battery**
Note that the battery voltage may exceed the rated voltage of the LED lamp while the battery is being charged and immediately after the charging is complete. Be sure to use the LED lamp on a voltage of $\pm 10\%$ the rated voltage, except the 230/240V AC/DC types on 250V AC/DC maximum.
- Full-wave rectification**
Since the LED lamp is AC/DC compatible, a diode bridge for rectification is not necessary. If the LED lamp is used on a full-wave rectification current through a diode bridge, the rectifier diodes will reduce the voltage, resulting in lower brightness.
- Single-phase half-wave rectification**
This is not suitable for the power source of LED lamps. Use constant-voltage DC power.

Noise

LED elements deteriorate due to extraneous noise, resulting in significant decrease in brightness, hue change, or failure of lighting. When such effects are anticipated, take a protection measure shown below, such as RC elements or a surge absorber.

Nameplate

When anti-rotation is not required, remove the projection from the nameplate using pliers.

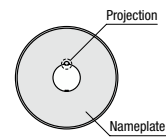

Handling

Do not expose the switch to excessive shock and vibration, otherwise the switch may be deformed or damaged, causing malfunction or operation failure.



[Protection Example 1] For AC circuit

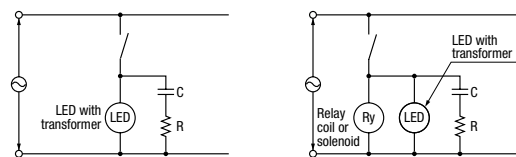

[Protection Example 2] For DC circuit

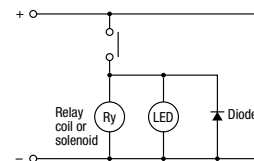

Countermeasures against Dim Lighting

- Leakage current through transistors or a contact protection circuit may cause the LED lamp to illuminate dimly even when the output is off.
- When the LED lamp is illuminated by a transistor output, take the following measure.

[Circuit Example]

Connect shunt resistor R in parallel with the LED lamp.

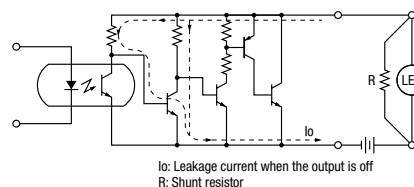

APEM

Switches & Pilot Lights

Control Boxes

Emergency Stop Switches
Enabling Switches

Safety Products

Explosion Proof

Terminal Blocks

Relays & Sockets

Circuit Protectors

Power Supplies

LED Illumination

Controllers

Operator Interfaces

Sensors

AUTO-ID

Flush Silhouette

ø16

ø22

ø30

Miniature

Pilot Lights

HW

TW

YW

Ordering Information

- When ordering, specify the Part No. and quantity.
- Replacement contact blocks are supplied in a package containing 10 pieces.



Download catalogs and CAD from <http://eu.idec.com/downloads>

B-300