

HE2B

Enabling Switches

HE2B Redundant (Double) Basic Enabling Switch

Overview

Key features:

- 3-position functionality (OFF – ON –OFF) as required for manual robotic control
- Ideally suited for use as enabling (aka “deadman”) switch on teach pendants
- Provides a high level of safety based on human behavioral studies that determine personnel may squeeze OR let go when presented with a panic situation
- Snap acting contacts from Off→On (1→2)
- Positive action contacts from On→Off (2→3) ensure no contact welding (per EN60947-5-1 / IEC60947-5-1)
- Contacts will not re-close when released from Off→On (3→1) (per IEC60204-1; 9.2.5.8)
- Multiple contacts for enhanced reliability
- Monitoring contacts in addition to main load contacts
- Available with or without rubber cover (cover provides IP65 watertight seal)



XW Series E-Stops

Interlock Switches



Part Numbers

Style	Number of Contacts			Part Number
	3 Position Switch	Push Monitor Switch	Return Monitor Switch	
Without Rubber Cover	2	0	0	HE2B-M200
	2	1	1	HE2B-M211
	2	2	2	HE2B-M222
With Rubber Cover	Yellow	2	0	HE2B-M200PY
		2	1	HE2B-M211PY
		2	2	HE2B-M222PY
	Black	2	0	HE2B-M200PB
		2	1	HE2B-M211PB
		2	2	HE2B-M222PB
	Gray	2	0	HE2B-M200PN1
		2	1	HE2B-M211PN1
		2	2	HE2B-M222PN1

Enabling Switches

Safety Control Relays

Accessories

Replacement Rubber Cover

Apperance	Color	Part Number	Material
	Yellow	HE9Z-D2Y	Silicon Rubber
	Black	HE9Z-D2B	
	Gray	HE9Z-D2N1	NBR/PVC Polyblend

Light Curtains

AS-Interface Safety at Work

Enabling Switches HE2B

Specifications

Conforming to Standards	UL508 (UL recognized), CSA C22.2, No. 14 (c-UL recognized), IEC/EN 60947-5-1, IEC/EN 60947-5-8 (TÜV approval)	
Application Standards	ISO 12100-1, -2, EN 12100-1, 2 / EN 292, IEC 60204-1 / EN 60204-1 ISO11161 / prEN 11161, ISO10218 / EN 775, ANSI / RIA R15.06, ANSI B11.19	
Operating Temperature	-25 to +60°C (no freezing)	
Operating Humidity	45 to 85% RH (no condensation)	
Storage Temperature	-40 to +80°C (no freezing)	
Pollution Degree	2 (inside of panel/contact side) 3 (outside of panel/operating side)	
Contact Resistance	50mΩ maximum	
Insulation Resistance	Between live and dead metal parts: 100MΩ maximum Between positive and negative live parts: 100MΩ minimum	
Impulse Withstand Voltage	2.5kV	
Operating Frequency	1200 operations/hour	
Mechanical Life	Position 1→2: 1,000,000 operations minimum Position 1→2→3→1: 100,000 operations minimum	
Electrical Life	100,000 (at full rated load)	
Shock Resistance	Operating Extremes	150m/s ² (15 G)
	Damage Limits	1000m/s ² (100 G)
Vibration Resistance	Operating Extremes	5 to 55Hz, amplitude 0.5mm minimum
	Damage Limits	16.7Hz, amplitude 1.5mm minimum
Terminal	0.110" quick connect / solder terminal	
Recommended Wire Size	0.5mm ² maximum / 1 line (20AWG)	
Solder Heat Resistance	310 - 350°C / 3 seconds maximum	
Terminal Pulling Strength	20N minimum	
Recommended Screw Torque	0.5 to 0.8Nm	
Degree of Protection	with rubber cover: IP65, without rubber cover: IP40 (IEC 60529),	
Conditional Short-Circuit Current	50A (250V)	
Recommended Short Circuit Protection	250V/10A fast blow fuse (IEC 60127-1)	
Circuit Opening Force	60N minimum (button return monitor & button push monitor)	
Actuating Force (Operating)	500N minimum	
Weight	Approx. 26g (without cover), 30g (with cover)	

Contact Ratings

Rated Insulation Voltage (Ui)		250V				
Thermal Current (Ith)		3A				
Rated Operating Voltage (Ue)		30V	125V	250V		
Rated Operating Current (Ie)	3 Position Switch	AC	Resistive Load (AC-12)	–	1A	0.5A
			Inductive Load (AC-15)	–	0.7A	0.5A
		DC	Resistive Load (DC-12)	1A	0.2A	–
			Inductive Load (DC-13)	0.7A	0.1A	–
	Push/return Monitor Switch (NC Contacts)	AC	Resistive Load (AC-12)	–	2.5A	1.5A
			Inductive Load (AC-15)	–	1.5A	0.75A
		DC	Resistive Load (DC-12)	2.5A	1.1A	0.55A
			Inductive Load (DC-13)	2.3A	0.55A	0.27A
Contact Configuration	3 Position Switch		2 contacts (DPDT)			
	Return Monitor Switch		0 ~ 2 contacts (NC)			
	Push Monitor Switch		0 ~ 2 contacts (NC)			



Minimum applicable load (reference) = AC/DC3V • 5mA (for reference only)

Overview | XIV Series E-Stops | Interlock Switches | **Enabling Switches** | Safety Control Relays | Light Curtains | AS-Interface Safety at Work

HE2B Enabling Switches

Overview

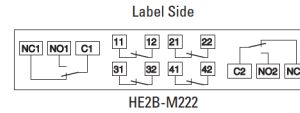
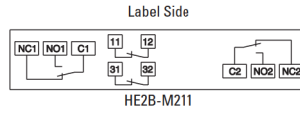
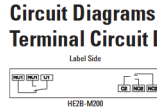

XW Series E-Stops

Operating Characteristics
Operating Characteristics (without rubber cover/center of button being pushed)

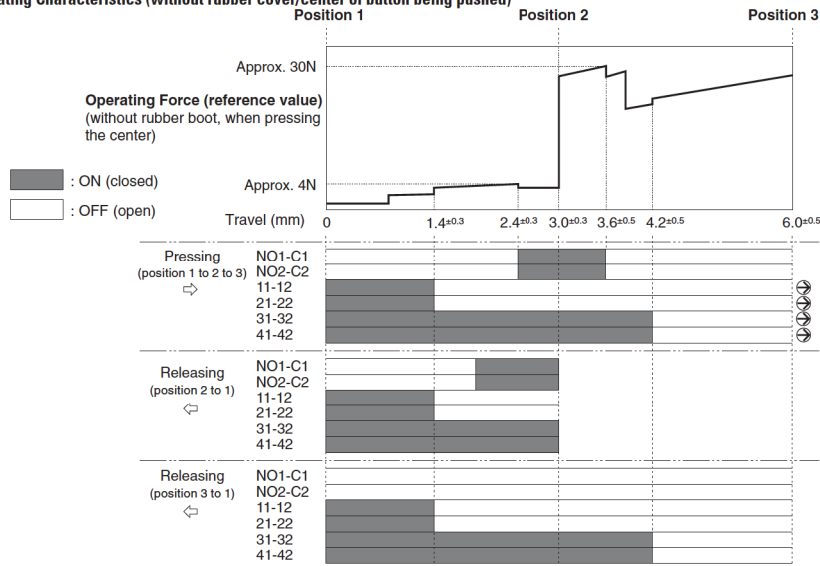

Interlock Switches

Enabling Switches

Safety Control Relays



Using rubber boot will change the operating force depending on the operating temperature.

Light Curtains

AS-Interface Safety at Work

Dimensions (mm)
Without Rubber Cover

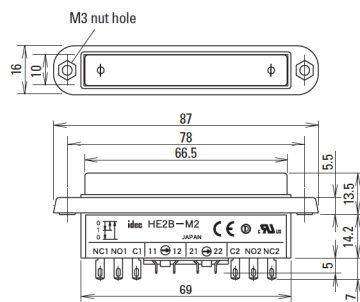

With Rubber Cover

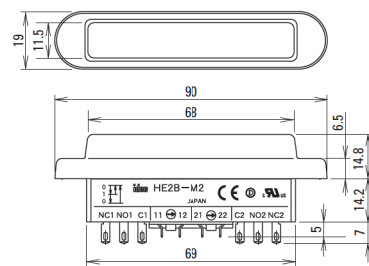

Mounting Hole Layout

