

HE5B

Enabling Switches

HE5B ø16mm Redundant Contact Pushbutton Enabling Switch

Key features:

- Ergonomically-designed OFF-ON-OFF 3-position operation
- Easy recognition of position 1 → 2 transition, made possible by snap action switch
- Sufficient load difference is provided for shifting from position 2 → 3
- Light force needed to maintain position 2, so that operators can easily use the enabling switch
- The switch does not turn ON when being released from position 3 (OFF when pressed) to position 1 (OFF when released) (IEC60204-1, 9.2.5.8)
- Two contacts are provided for safety
- IP65 (using the waterproof rubber cover)
- Mounts in a 16mm (5/8") round hole

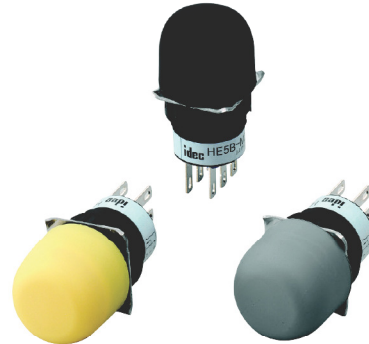

Overview

XW Series E-Stops

Interlock Switches

Enabling Switches

Safety Control Relays

Light Curtains

AS-Interface Safety at Work

Part Numbers

Style	Color	Part Number
	Yellow	HE5B-M2PY
	Black	HE5B-M2PB
	Gray	HE5B-M2PN1

 NBR/PVC cover comes in gray only.

Accessories

Replacement Rubber Cover

Appearance	Part Number	Material
	Silicon Rubber	Yellow HE9Z-D5Y
	NBR/PVC Polyblend	Black HE9Z-D5B
		Gray HE9Z-D5N1

Lock Nut Tool

Appearance	Part Number	Material
	MT-001	Metal

Grip Housing

Appearance	Part Number
	HE9Z-GSH51

See page 417 for more information.

Specifications

Conforming to Standards	UL508 (UL recognized), CSA C22.2, No. 14 (c-UL recognized) IEC/EN 60947-5-1, IEC/EN 60947-5-8 (TÜV approval)
Application Standards	ISO 12100-1, -2, EN 12100-1, 2 / EN292, IEC 60204-1 / EN 60204-1, ISO 11161 / prEN 11161, ISO 10218 / EN 775, ANSI/RIA R15.06, ANSI B11.19
Operating Temperature	Silicon rubber boot: -25 to 60°C (no freezing) NBR/PVC Polyblend rubber boot: -10 to 60°C (no freezing)
Relative Humidity	45 to 85% RH (no condensation)
Storage Temperature	-40 to +80°C (no freezing)
Operating Environment	Degree of pollution: 2 (panel inside/terminal side) Degree of pollution: 3 (panel outside/operator side)
Contact Resistance	50 mΩ maximum (initial value)
Insulation Resistance (DC megger)	Between live and dead metal parts: 100 MΩ minimum Between terminals of different pole: 100 MΩ minimum
Impulse Withstand Voltage	1.5 kV

Enabling Switches

HE5B

Specifications con't

Operating Frequency	1200 operations per hour
Mechanical Life	Position 1→2→1: 1,000,000 operations minimum Position 1→2→3→1: 100,000 operations minimum
Electrical Life	100,000 operations minimum
Shock Resistance	Operating extremes: 150 m/s ² (15 G) Damage limits: 500 m/s ² (50 G)
Vibration Resistance	Operating extremes: 5 to 55 Hz, amplitude 0.5 mm minimum Damage limits: 5 to 55 Hz, amplitude 0.5 mm minimum
Terminal Style	Solder Terminal
Recommended Wire Size	0.5 mm ² maximum per line (20AWG)
Solder Heat Resistance	310 ~ 350°C, 3 seconds maximum
Terminal Pulling Strength	20 N minimum
Recommended Tightening Torque of Locking Ring	0.29 to 0.49 N·m
Degree of Protection	IP65
Conditional Short-circuit Current	50A (250V) (Use 250V/10A fast acting type fuse for short circuit protection.)
Operator Strength	250N minimum (when pressing the entire surface of the operator)
Weight (approx.)	9 g

Current Ratings

Rated Insulation Voltage (Ui)		125V	
Thermal Current (Ith)		3A	
Rated Operating Voltage (Ue)		30V	125V
Rated Operating Current (Ie)	AC	Resistive Load (AC-12)	0.5A
		Inductive Load (AC-15)	0.3A
	DC	Resistive Load (DC-12)	1A
		Inductive Load (DC-13)	0.7A
Contact Configuration		2 contacts (DPDT)	



Minimum applicable load (reference): 5V AC/DC, 5mA.

Circuit Diagrams

Terminal Arrangement (Bottom View)

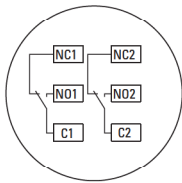

- 3 position switch: 2 contacts, terminal no. = between NO1-C1, between NO2-C2
- Use between NO-C for OFF→On→OFF 3 position switch (NC is not used).

Overview

XV Series E-Stops

Interlock Switches

Enabling Switches

Safety Control Relays

Light Curtains

AS-Interface Safety at Work

HE5B

Enabling Switches

Operating Characteristics

Operating Characteristics (without rubber cover/center of button being pushed)

Overview

XW Series E-Stops

Interlock Switches

Enabling Switches

Safety Control Relays

Light Curtains

AS-Interface Safety at Work

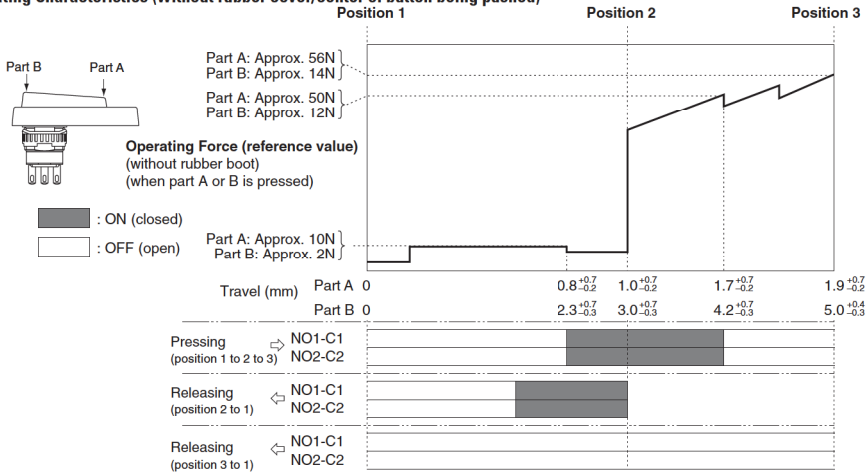

Operating load depends on ambient temperature.

Dimensions (mm)
With Rubber Cover

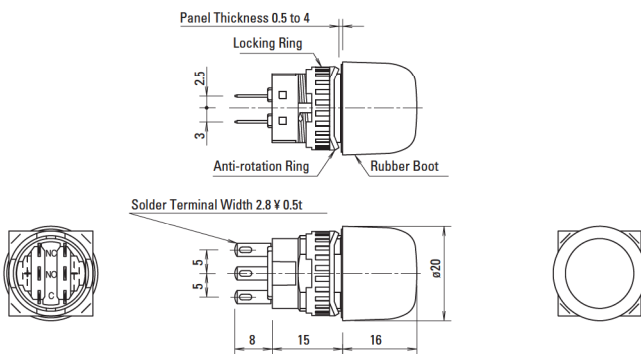

Mounting Hole Layout

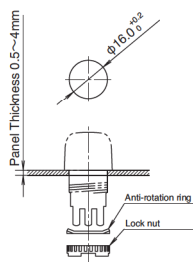

1. Recommended tightening torque for Locking Ring: 0.29 to 0.49 N·mm.
2. Use a lock nut tool to screw on the lock nut (see page 400).